

Digital Temperature Controller

DX series

INSTRUCTION MANUAL

Thank you for purchasing HANYOUNG product.

Please check whether the product is the exactly same as you ordered.
Before using the product, please read this instruction manual carefully.
Please keep this manual where you can view at any time



HANYOUNGNUX CO.,LTD

HEAD OFFICE 1381-3, Juan-Dong, Nam-Gu Incheon, Korea.
TEL:(82-32)876-4697 FAX:(82-32)876-4696 <http://www.hynux.net>

PT. HANYOUNG ELECTRONIC INDONESIA

INDONESIA Jl. cempaka blok F16, No.02 Delta Silicon II Cikarang Bekasi Indonesia
FACTORY TEL : 62-21-8911-8120~4 FAX : 62-21-8911-8126

Safety information

Alerts declared in the manual are classified to Danger, Warning and Caution by their criticality

	DANGER	DANGER indicates an imminently hazardous situation which, if not avoided, will result in death or serious injury
	WARNING	WARNING indicates a potentially hazardous situation which, if not avoided, could result in death or serious injury
	CAUTION	CAUTION indicates a potentially hazardous situation which, if not avoided, may result in minor or moderate injury

DANGER

Do not touch or contact the input/output terminals because they may cause electric shock.

WARNING

- If the product is used with methods other than specified by the manufacturer, then it may lead to injury or property damage.
- Please install an appropriate protective circuit on the outside if malfunction or an incorrect operation may be a cause of leading to a serious accident.
- Since this product does not have the power switch or a fuse, please install those separately on the outside. (Fuse rating: 250V 0.5A)
- To prevent damage or failure of this product, please supply the rated power voltage.
- To prevent electric shock or equipment failure, please do not turn on the power until completing wiring.
- Since this is not explosion-proof structure, please do not use in a place where combustible or explosive gas is around.
- Never disassemble, modify, or repair the product. There is a possibility of malfunction, electric shock, or a risk of fire.
- Please turn off the power when mounting/dismounting of the product. This is a cause of electric shock, malfunction, or failure.
- Since there is a possibility of electric shock, please use the product as mounted on a panel while the power is being supplied.

CAUTION

- The contents of the instruction manual are subjective to change without prior notice.
- Please make sure that the specification is the same as what you have ordered.
- Please make sure that the product is not damaged during shipping.
- Please use this product in a place where the ambient operating temperature is 0 ~ 50 °C (40 °C max, closely installed) and the ambient operating humidity is 35 ~ 85 % R.H (without condensation).
- Please use this product in a place where corrosive gas (such as harmful gas, ammonia, etc.) and flammable gas do not occur.
- Please use this product in a place where there is no direct vibration and a large physical impact to the product.
- Please use this product in a place where there is no water, oil, chemicals, steam, dust, salt, iron or others.
- Please do not wipe this product with organic solvents such as alcohol, benzene and others. (Please use mild detergent)
- Please avoid places where excessive amounts of inductive interference and electrostatic and magnetic noise occur.
- Please avoid places where heat accumulation occurs due to direct sunlight or radiant heat.
- Please use this product in a place where the elevation is below 2,000 m.
- Please make sure to inspect the product if exposed to water since there is a possibility of electric leakage or a risk of fire.
- For thermocouple (TC) input, please use a prescribed compensation lead wire. (There is a temperature error if a general lead is used.)
- For resistance temperature detector (RTD) input, please use a small resistance of lead wire and the 3 lead wires should have the same resistance. (There is a temperature error if the 3 lead wires do not have the same resistance.)
- Please put the input signal wire away from the power lines and load lines to avoid the effect of inductive noise.
- The input signal wires and output signal wires should be separated from each other. If it is not possible, please use shielded wires for the input signal wires.
- For thermocouple (TC), please use ungrounded sensors. (There is a possibility of malfunction of product by electric leakage if a grounded sensor is used.)
- If there is a lot of noise from the power line, installing an insulated transformer or a noise filter is recommended. The noise filter should be grounded on the panel and the lead wire between the output of the noise filter and the power terminal of the instrument should be as short as possible.

- It is effective against noise if making the power lines of the product the twisted pair wiring.
- Please make sure the operation of the product before using since the product may not operate as it intends if the alarm function is not properly set.
- When replacing the sensor, please turn off the power.
- In case of the high frequent operation such as proportional operation, please use an auxiliary relay since the life span of the output relay will be shortened if it connects to the load without the rated margin. In this case, SSR output is recommended.
 - * Electromagnetic switch: proportion cycle: set 20 sec min.
 - * SSR: proportion cycle: set min.1 sec
 - * Contact output life expectancy:
 - Mechanical - 1 million times min. (without load)
 - Electrical - 100 thousand times min. (250 V a.c 3A: with rated load)
- Please do not connect anything to the unused terminals.
- Please connect wires properly after making sure the polarity of terminal.
- Please use a switch or breaker (IEC60947-1 or IEC60947-3 approved) when the product is mounted on a panel.
- Please install a switch or break near the operator to facilitate its operation.
- If a switch or breaker is installed, please put a name plate that the power is off when the switch or breaker is activated.
- In order to use this product properly and safely, we recommend periodic maintenance.
- Some parts of this product have limited expected life span and aged deterioration.
- The warranty of this product (including accessories) is 1 year only when it is used for the purpose it was intended under normal condition.
- When the power is being supplied there should be a preparation time for the contact output. Please use a delay relay together when it is used as a signal on the outside of interlock circuit or others.
- When the user replaces with a spare unit due to product failure or other reason, please check the compatibility since the operation can be varied by the difference of setting parameters even though the model name and code are the same.
- Before using a temperature controller, please check if there is a temperature difference between PV of the temperature controller and the actual temperature. If there is a temperature difference, please correct the temperature difference with using the input correct parameter "SL-5".

Suffix code

Model	Code	Description
DX	□ □ □ □ □ □ □ □	Digital temperature controller
Dimension	2	48(W) × 96(H) mm
	3	96(W) × 48(H) mm
	4	48(W) × 48(H) mm
	7	72(W) × 72(H) mm
	9	96(W) × 96(H) mm
Input	K	K thermocouple
	J	J thermocouple
	R	R thermocouple
	D	RTD: KPt 100 Ω
	P	RTD: Pt 100 Ω
	V	1 - 5 V d.c
	C	4 - 20 mA d.c
	F	0 - 10 V d.c
Control output	M	Relay contact output
	C	Current output (4 - 20 mA d.c)
	S	S.S.R (voltage pulse output, 12 V d.c)
Alarm output	S	Alarm output: 1 contact (model: DX4)
	W	Alarm output: 2 contacts(all model except DX4)
Option	A	Retransmission output (4 - 20 mA d.c)
	N	None (no retransmission output for DX4, DX7)
Control operation *1	R	Reverse operation control(heating control)
	D	Direct operation control(cooling control)
Power supply	•	100 - 240 V a.c
	C	24 V d.c/a.c

*1 : The control operation can be changed in the parameter, SL9, and the default is "reverse operation control (R)".

Specification

Power supply voltage		100 – 240 V a.c (±10%), 50/60 Hz
Power consumption		4.5 W max
Input	Type	Refer to input table
	Sampling cycle	250 ms
	Indication accuracy	± 0.5 % (refer to input type table)
	Allowable voltage	20 Vd.c for 1 minute
	Reference junction compensation accuracy	±3.5°C (0 ~ 50°C)
	Operation after input break	Up Scale
Control output	Relay	NO: 5 A 250 V a.c, 5A 30 V d.c (resistive load) NC: 3 A 250 V a.c, 1A 30V d.c (resistive load) Switching Life : 100 thousand times (without load)
	Voltage output	ON voltage: 12 V d.c min OFF voltage: 0.1 V d.c max Load resistance 600Ω min
	Current output	range: 3.2 ~ 20.8 mA Accuracy: ± 0.2 mA Load resistance 600Ω max
Retransmission output		range: 3.2 ~ 20.8 mA Accuracy: ± 0.2 mA Load resistance 600Ω max
Alarm output		5 A 250 V a.c, 5 A 30 V d.c (resistive load) Switching Life: 100 thousand times (without load)
Control	method	ON/OFF, PID control
	Output operation	Reverse operation, Direct operation
	Anti-reset windup	Auto(A=0), 0.1 ~ 100%
Insulation resistance		20 MΩ min (primary terminal – secondary terminal)
Dielectric strength		2,300 V a.c, for 1 minute (primary terminal – secondary terminal)
Operating environment	Temper. & humidity	0 ~ 50°C, 35 ~ 85% R.H (with no condensation)
	Environment	Refer to safety information

Part name and functions

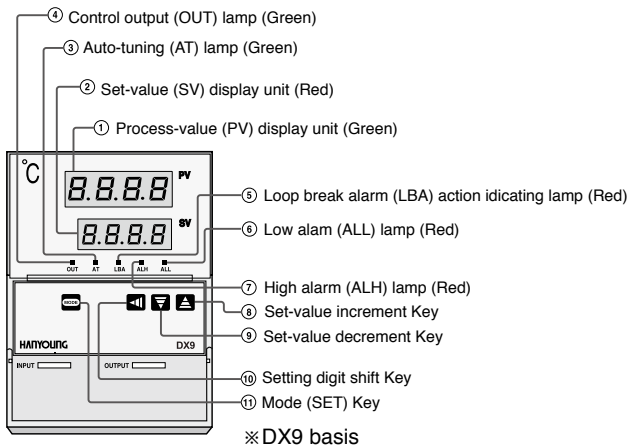

Operation

■ PV/SV display and SV setting modes

Process value (PV) display unit	Set-value (SV) display unit	Description
Process value (PV)	Set-value (SV)	Displays process-value. Set-value (SV) can be set ※1

※1 : Set-value (SV) is a control target, It is settable within the input range.

■ Normal setting mode

※ Press the key continuously for 3 sec.

Process value (PV) display unit	Name	Description
※1 ALH	High alarm (ALH)	Displays high alarm set-value.
※1 ALL	Low alarm(ALL)	Displays low alarm set-value.
P	Proportional band (P)	Set when proportional control is performed. Control becomes ON/OFF action with P set to "0".
A	Anti-reset windup (ARW)	Prevents overshoot and/or undershoot caused by integral action effect. It operates automatically (AUTO) if ARW is set to "0".
I	Integral time (I)	Eliminates offset occurring in proportional control. Integral action is OFF with this action set to "0".
D	Derivative time (D)	Prevents ripples by predicting output change thereby improving control stability. Derivative action is OFF with this action set to "0".
LBA	Control loop break alarm (LBA)	Indicates control loop break alarm setting. LBA is off if "0" is set.
C	Proportioning cycle (C)	Displays control output cycle (sec.).
HYS	Hysteresis (HYS)	Displays hysteresis of set-value for main output. (ON/OFF control)
※2 F-r	Full scale limit	This limits the maximum of retransmission output.
※3 U-r	Under scale limit	This limits the minimum of retransmission output.
LoC	Set data lock (LOC)	Turns the set data lock ON/OFF

※ 1 ALH and ALL are initialized if SL3 is changed.

※ 2 or ※ 3 is an option.

(The parameters are not shown if retransmission output is unavailable)
(The retransmission output option is not available for DX4, DX7.)

■ Initial set mode

- Press key and key simultaneously for 3 seconds to enter the setting mode.
- Press key for 3 seconds to enter the PV / SV setting mode.

⚠ Caution

The value in the parameter SL1 (input selection) cannot be changed. The SL1 is set according to the suffix code when ordering a product.

SL1 ----- PV display unit
[] [] [] [] ----- SV display unit
----- Input type selection (Fixed)

Set	Description
0000	1 - 5 V d.c or 4 - 20 mA
0001	K (CA)
0010	KPt100 Ω
0011	DIN Pt100 Ω
0100	R (PR)
0101	J (IC)
1111	0 - 10 V d.c

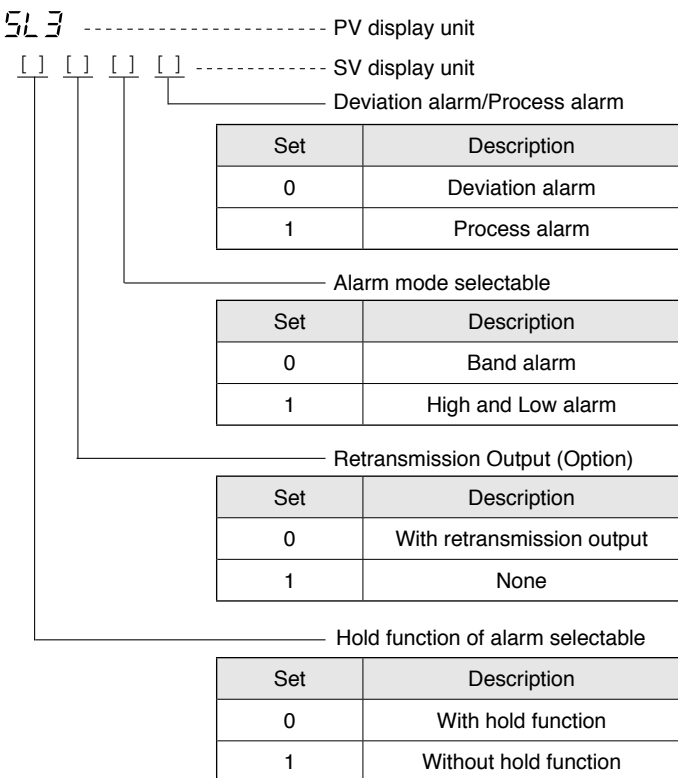
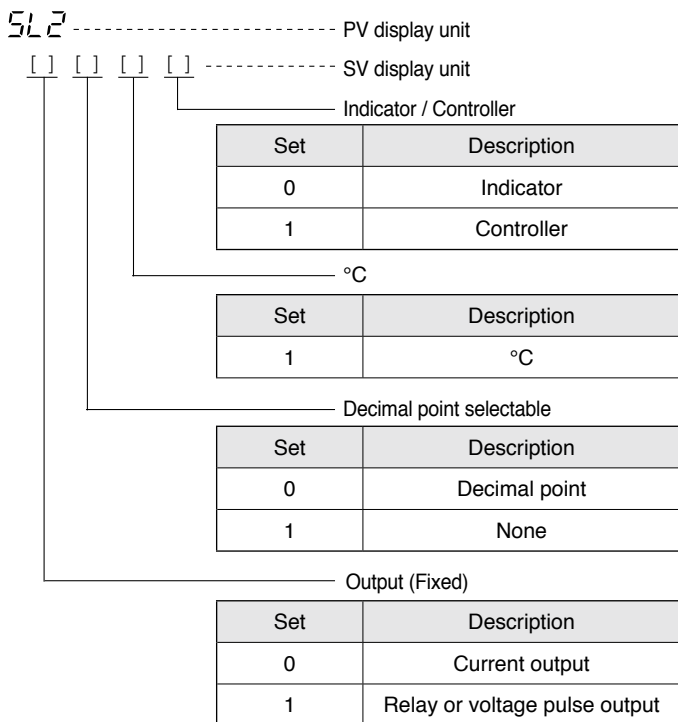

※ ALH & ALL will be initialized if you change the deviation alarm or process alarm at the SL3

PV display unit	Description	SV display unit (Setting range)	Remark
SL4	Decimal point position selection	0 ~ 4	If you want 000.0, set 0002 on SV display unit.
SL5	Input correction	-100 ~ 100 % of FS	
SL6	Hysteresis of high alarm (ALH)	0 ~ 10 % of FS	
SL7	Max. value of temperature setting range	Within input range	Refer to input type table
SL8	Min. value of temperature setting range	Within input range	Refer to input type table
SL9	Control operation direction	0, 1	0 : Reverse operation 1 : Direct operation
SL10	Hysteresis of low alarm (ALL)	0 ~ 10 % of FS	
SL11	Input filter	0 ~ 100 second	
SL12	Max. input scale setting	9999	Only for voltage input
SL13	Min. input scale setting	-1999	Only for voltage input
SL14	Delay time of high alarm (ALH)	0 ~ 100 second	
SL15	Delay time of low alarm (ALL)	0 ~ 100 second	

※ For DCV input, if SL12 and SL13 are changed, the parameters related to temperature are initialized.

Main functions

■ Control loop break alarm (LBA) function

● Setting procedure

Usually set the set-value of the LBA to a value of twice the integral time (I). The LBA can also be set by the auto-tuning (AT) function. In this case, the set-value is automatically set to a value of twice the integral time (I).

● Description of operation

LBA function starts to measure the time from the moment when the control output becomes 0% or 100%, and it detects the variation of the process value in LBA setting time and then it determines that LBA is ON or OFF by the variation.

- The LBA is ON if the process value is not increasing more than 2 °C within the LBA set-value when the control output is 100%. (In direct operation, the LBA is ON if the process value is not decreasing more than 2 °C.)
- The LBA is ON if the process value is not decreasing more than 2 °C within the LBA set-value when the control output is 0%. (In direct operation, the LBA is ON if the process value is not increasing more than 2 °C.)

● Causes of action

The LBA is activated under the following conditions.

- Controlled object trouble : Heater break, no power supply, incorrect wiring, etc.
- Sensor trouble : Sensor disconnected, shorted, etc.
- Actuator trouble : Burnt relay contact, incorrect wiring, relay contact not closed, etc.
- Output circuit trouble : Burnt internal relay contact, relay contact not open or closed, etc.
- Input circuit trouble : The process-value does not change even if input changes, etc.

※ If causes of the above trouble cannot be identified, check the control system.

● Cautions for control loop break alarm (LBA) function

- The LBA function is activated only when the control output is 0 % or 100 %. Therefore, the time from trouble occurrence till the activation of the LBA function equals the time of when the control output becomes 0 % or 100 % plus the LBA setting time.
- No LBA function is activated while the auto-tuning (AT) function is activated.
- The LBA function is influenced by disturbances (heat sources, etc) and as a result may be activated even if there is no trouble in the control system.
- If LBA setting time is too short or does not match the controlled object, the LBA may be turned ON/OFF or not be turned ON. In such case, set the setting time of LBA to be slightly longer.

■ Auto-tuning (AT) function

The Auto-tuning function automatically measures, computes and set the optimum P. I. D and ARW constants. The Auto-tuning function is activated any time from any process states after power-on, while temperature is rising and or when control is stabilized.

- After finishing settings other than PID and ARW, perform the Auto-tuning operation.
- Press the key and key at the same time then, A. T indication lamp flashes to start the Auto-tuning function.
- If Auto-tuning function ends, the A. T indication lamp stops flashing automatically. When checking the auto-tuned value, press the .
- When changing the constants automatically set by the Auto-tuning, changes each constant according to each parameter setting
- When you want Auto-tuning function to be suspended, press the key and key simultaneously, then the A. T indication lamp stops flashing to release Auto-tuning function. In this case P. I. D and ARW values are not changed (Maintain the value before the Auto-tuning started)
- When you want to changes the SV (set-value) during Auto-tuning, suspend it and perform PID control using the values before Auto-tuning started.

■ Set data lock function

The set data lock function is used to prevent changing of each set-value by the front key and the activation of the auto-tuning function, i.e., prevent misoperation after setting has ended.

For set data lock, display by pressing the , then set the following value in accordance with setting procedure thereby enabling data lock ON or OFF.

0000 : No set data locked.

0001 : Only set-value (SV) can be changed with the set data locked.

Setting other than the above locks all set date and A.T function.

■ Alarm function * Each alarm operation can be set as shown below.

(▲ : Set-value (SV) △ : Alarm set-value)

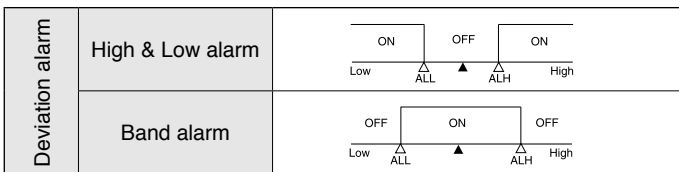

This alarm setting is that the alarm is activated if a few °C is higher or low than set-value. For example, if the set-value of the temperature is 200 °C and a system is designed to have that the high alarm (ALH) is activated when the process value is 205 °C and the low alarm is activated when the process value is 190 °C then set the high alarm (ALH) 5 °C, and set the low alarm (ALL) 10 °C. If the set-value is changed to 300 °C, the high alarm is activated at 305 °C and the low alarm is activated at 290 °C.

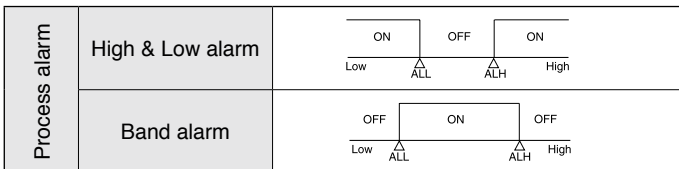

Note) Regardless of the set-value, the high or low alarm is activated at the alarm set-value.
* For the band alarm, the relay of the low alarm (ALL) is not activated but the relay of the high alarm (ALH) is activated.

■ Overscale and underscale

- If a process value exceeds the maximum temperature range due to upscale (input break) or etc., the process value (PV) display unit flashes overscale display "".
- If a process value reaches below the minimum temperature range, the process value (PV) display unit flashes underscale display "".

■ Model information after power on

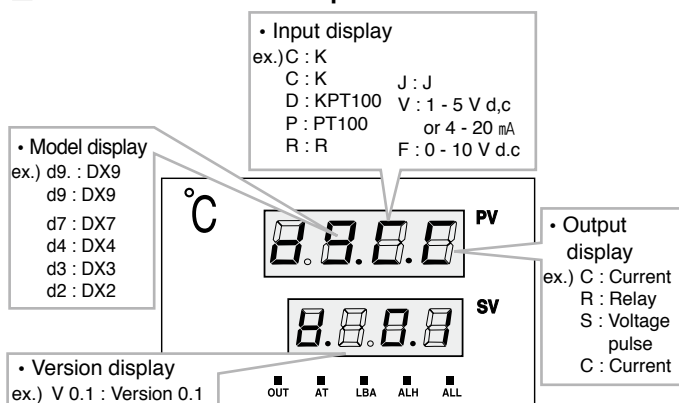

■ Control operation direction

Set a control operation at the SL9.

- ① 0 : Reverse operation for heating control
- ② 1 : Direct operation for cooling control

■ Input filter

Select the input filter calculation time in SL11. The input signal may have noise that can be a cause of fluctuation of the process value. This function eliminates the fluctuation by displaying the calculated value in preset time. When "0" is set, the input filter is turned OFF.

■ Input scale

Set a range of input voltage for DCV input.

For instance, SL1 = 0000 (1~5 V DCV) input, SL12 = 100.0, SL13 = 0.0 will be displayed as below.

Input Voltage	1 V	3 V	5 V
Display	0.0	50.0	100.0

■ Alarm delay time

Set high and low alarm delay time at SL14 and SL15 respectively. Even when alarm condition is met, if delay is set at SL14 and SL15, the alarm is triggered after those settings are exceeded. However, alarm off is not related to the delay setting.

■ Anti reset wind-up

Set the anti reset wind-up with "A" parameter.

- ① Control in case of A = Auto (0)

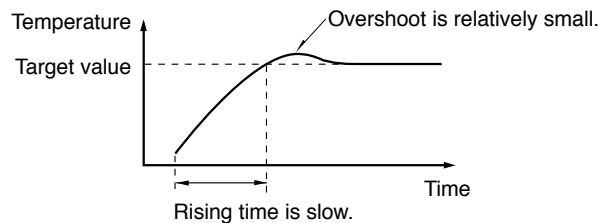

- ② In case of a set value for temperature on "A" parameter.

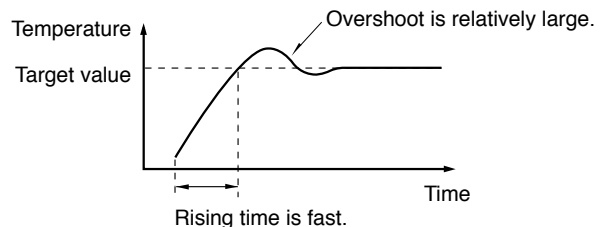

* If "A" is too small, large overshoot or undershoot occurs. Set the value the same as the proportional value.

Input type

Classification	SL1	Input type	Range	
			1°C (SL2 : X1XX)	0.1°C (SL2 : X0XX)
Thermocouple (T.C)	0001	K	- 50 ~ 1300 °C	- 50.0 ~ 999.9 °C
	0101	J	- 50 ~ 600 °C	- 50.0 ~ 600.0 °C
	0100	R	0 ~ 1700 °C	0.0 ~ 999.9 °C
RTD	0010	KPt100	- 199 ~ 500 °C	- 199.0 ~ 500.0 °C
	0011	Pt100	- 199 ~ 640 °C	- 199.0 ~ 640.0 °C
DCV	0000	1 - 5 V, 4 - 20 *1	- 1999 ~ 9999	Decimal point is set by SL4
	1111	0 - 10 V *1	- 1999 ~ 9999	

* Accuracy : ± 0.5 % of FS

*1 : ± 1 % of FS

Dimension & Panel cutout & Connections

Unit : mm

DX2

● Appearance

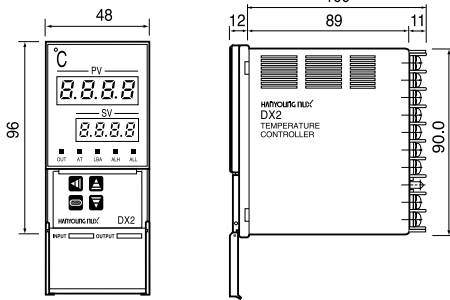

● Panel cutout

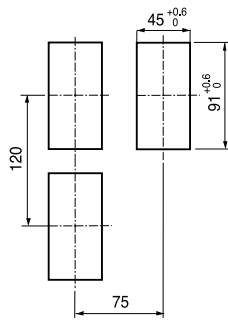

● Connection diagram

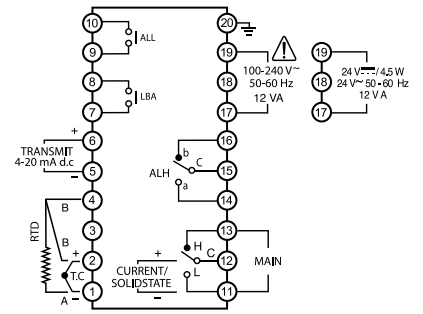

DX3

● Appearance

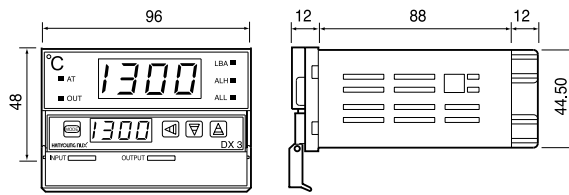

● Panel cutout

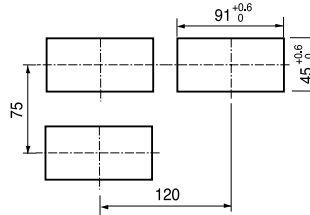

● Connection diagram

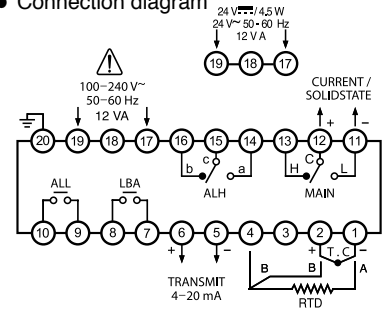

DX4

● Appearance

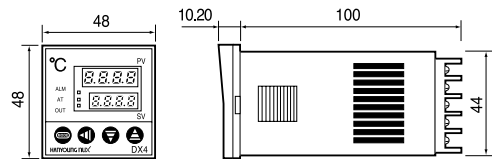

● Panel cutout

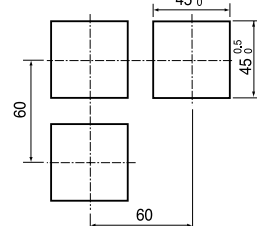

● Connection diagram

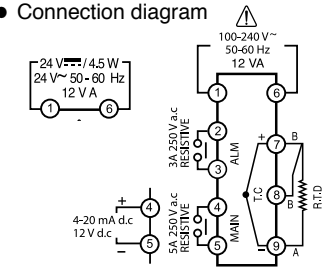

DX7

● Appearance

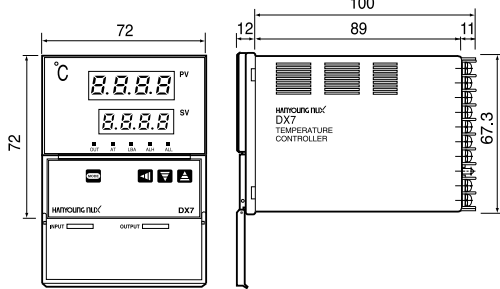

● Panel cutout

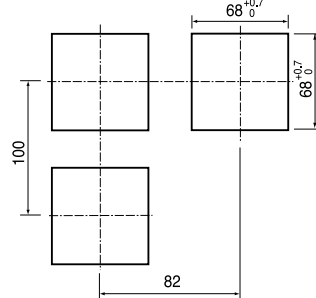

● Connection diagram

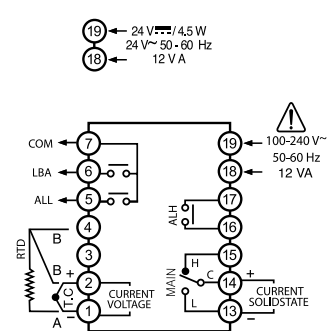

DX9

● Appearance

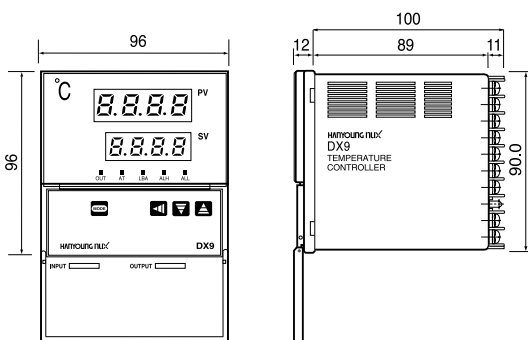

● Panel cutout

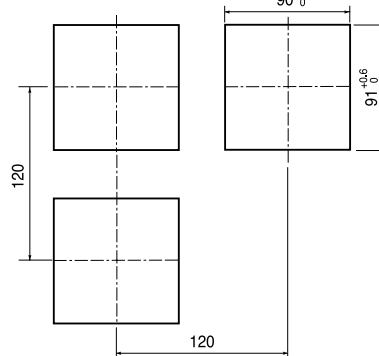

● Connection diagram

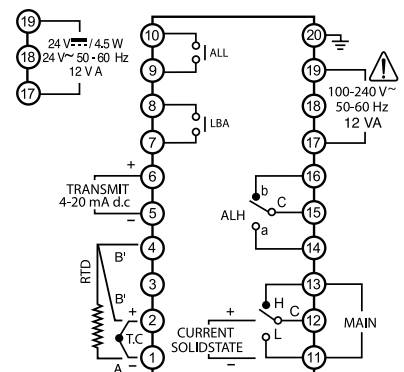

※ Reference : CURRENT : 4 - 20 mA d.c., SOLID STATE : 12 V.d.c Min.

※ There is no earth terminal for DX4 and DX7.

Be careful this matter when you use.

Graphic Recorder GR100

Bright color TFT LCD & Touch panel system



FEATURES

- Bright color TFT LCD & Touch panel system
- Various input types
(T/C 12 kinds, R.T.D 2 kinds, DC voltage 3 kinds)
- Horizontal & Vertical trend, Text, Bar graph, History view
- 6 or 12 channel analog inputs, 6 external inputs (D/I), 6 or 12 relay outputs (D/O)
- 4 alarms per channel
- Computing, Function, Conversion function
- RS232, RS422/485, USB, ETHERNET communication
(MODBUS-RTU, MODBUS on TCP)
- Support Large capacity SD memory card (FAT 16 / 32)



Programmable Temperature & Humidity Controller



TH500

- High Accuracy Control
- History management
- 300 pattern setting
- Temperature & Humidity PID group
- Convenient communication data management
- Various output type

Programmable Temperature Controller



TD500

- Touch screen color LCD screen
- 4 P.I.D zone
- Universal Input
- Time signal 8 points
- Alarm output 4 points
- Heating / Cooling control output
- Contact input (D.I) 8 points/ Contact output (D.O) 16 points
- Communication function