

TH500 • TH300

Programmable Temperature and Humidity Controller

Manual

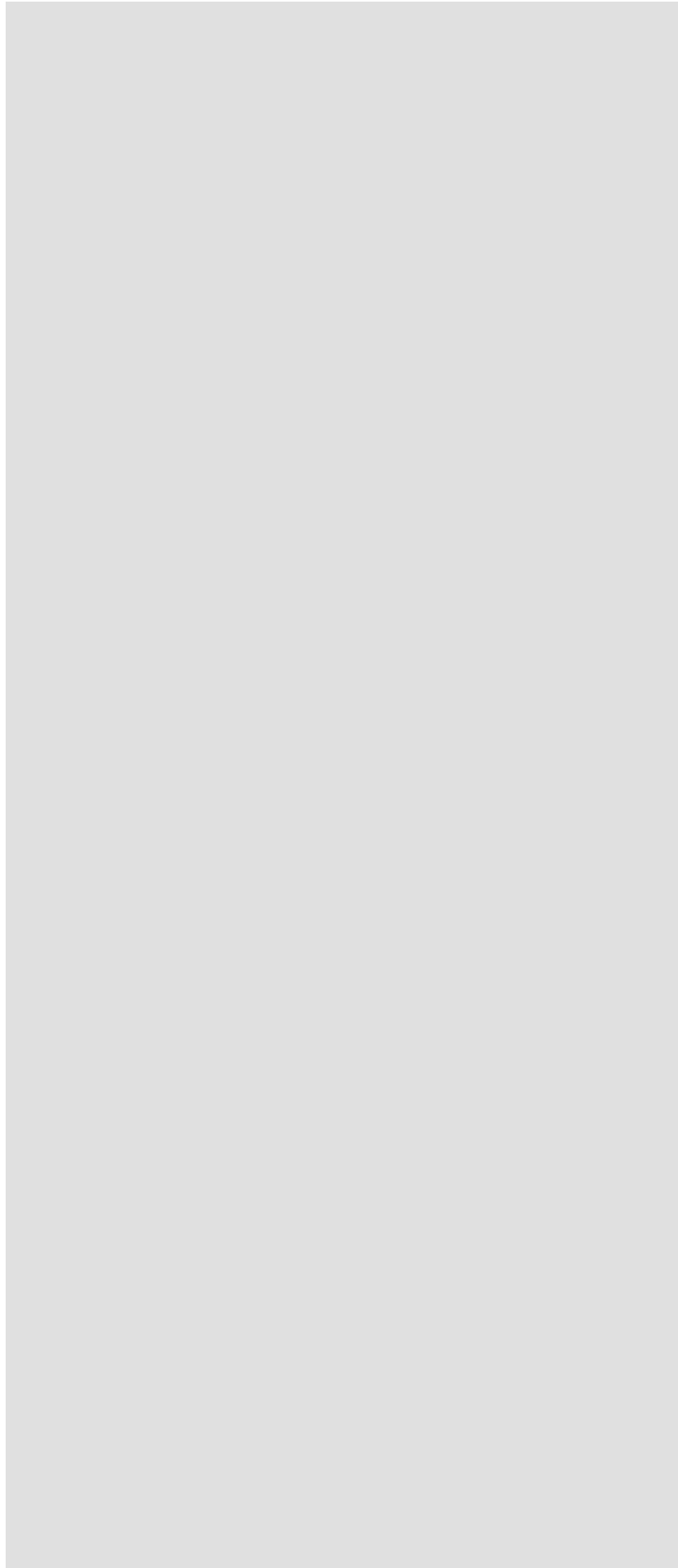



HEAD OFFICE

1381-3, Juan-Dong, Nam-Gu Incheon, Korea

TEL: (+82-32) 876-4697 FAX: (+82-32) 876-4696

<http://www.hynux.net> E-mail. overseas@hynux.com

table of contents

1 before starting	1.1 Checking the product	5
	1.2 Safety information	7
	1.3 Quality guarantee	8
2 Installation method	2.1 How to install	9
	2.2 Suffix Code	10
	2.3 Dimension and panel cutout	11
	2.4 Connection diagram	14
	2.5 Communication connection	18
3 Setting and operating	3.1 Initial screen	20
	3.2 How to input	21
	3.3 The name of each part on the operating screen	26
	3.4 Fix control	30
	3.5 Program running	32
	3.6 PID Auto-tuning	34
	3.7 Graph display and setting	35
	3.8 Error indication	36
4 Displays	4.1 Working display	37
	4.2 Function setting display	38
	4.3 System setting screen	38
5 Function setting	5.1 Operation setting	41
	5.2 Program setting	42
	5.3 Date/time reservation setting	55
	5.4 Graph/Save setting	56
6 System setting	6.1 Sensor type setting	59
	6.2 Control output setting	63
	6.3 Retransmission output setting	66
	6.4 Inner signal and alarm setting	67
	6.5 P.I.D setting	71
	6.6 Digital input (D.I) configuration setting	74
	6.7 Digital output (D.O) configuration setting	76
	6.8 Communication setting	80
	6.9 Other setting	81
7 Simple example	7.1 Input related setting	82
	7.2 Output related setting	84
	7.3 Inner signal setting	85
	7.4 Fix control	86
	7.5 Program control	88
8 Specification	8.1 Input	91
	8.2 Output	91
	8.3 Communication	92
	8.4 Power supply	92
	8.5 Functions	93
	8.6 Touch LCD	94
	8.7 Operation environment	94
9 Accessories (sold separately)	EM310 USB memory storage device	95

1 Before Starting

Thank you for the purchase of HANYOUNG Temperature and Humidity Controller (Model# TH500/TH300).

This manual contains the function of product, install method, caution information and the way of using this controller. So please read this manual before using it.

And also please make this manual to be delivered to the final user and to be placed where can be found and seen easily

(Contents of this user manual can be edited without prior notice for improvement and modification of the product.)

* Information in this manual may changed without prior notification.

* If you have any question or find error in this manual, please contact us

* Copying or reprinting this manual without notifying us is prohibited.

■ Service(A/S)

* Please send product to the nearest distributor, agency or head quarter for A/S.

* When willing to have an on-site A/S, please call our A/S center and make an appointment.

* Before making an appointment for A/S, please check out our web and search for the same problem in our FAQ.

HANYOUNG NUX

#1381-3, Juan-Dong, Nam-ku, Incheon, Korea

TEL : (+82-32) 876-4697

FAX : (+82-32) 876-4696

URL : <http://www.hynux.net>

E-mail : overseas@hynux.com

1.1 Checking the product

After purchasing the product, please check for the correct model type and check for any abnormal parts/scratches on the outside. If it is incorrect model type or find any abnormal parts/scratches on the outside, please contact to our nearest sales office.

1.1.1 TH500

● Standard

1)TH500-1NN

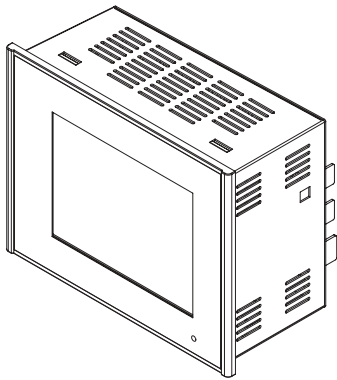

Standard Type

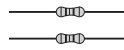

Resistance
250 Ω × 2

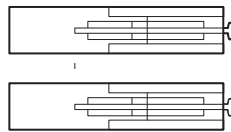

Fixing bracket

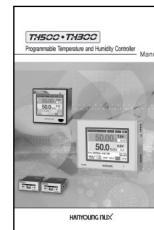

Manual

● Additional

1)TH500-21N

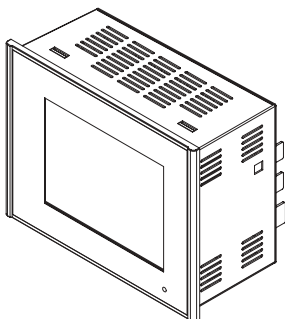

Additional Type

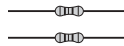

Resistance
250 Ω × 2

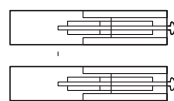

Fixing bracket

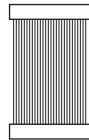

40p cable

I/O Board 1

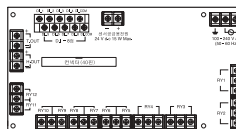

Manual

2)TH500-24N

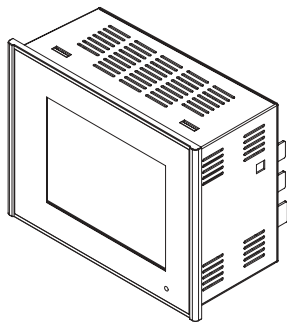

Additional Type

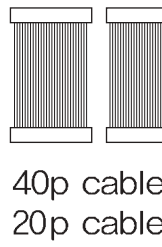
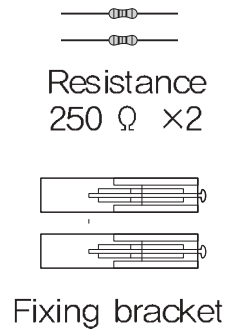

I/O Board 1

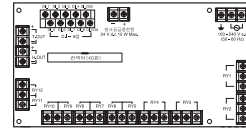

I/O Board 2

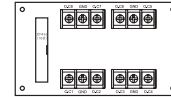

Manual

3)TH500-25N

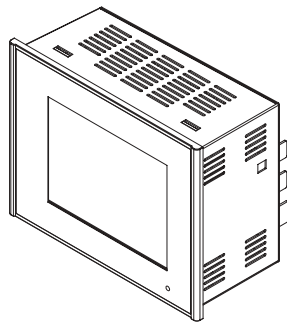

Additional Type

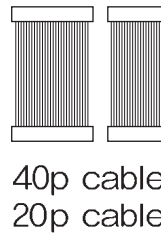

I/O Board 1

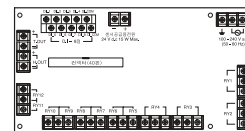

I/O Board 3

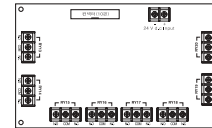

Manual

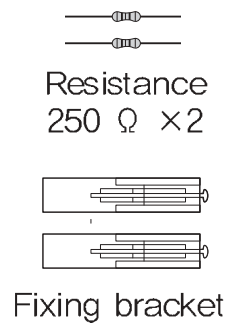
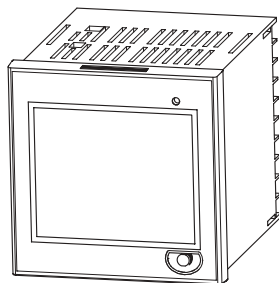

1.1.2 TH300



Manual

1.2 Safety information

Alerts declared in the manual are classified to Danger, Warning and Caution by their criticality

 Danger	DANGER indicates an imminently hazardous situation which, if not avoided, will result in death or serious injury
 Warning	WARNING indicates a potentially hazardous situation which, if not avoided, could result in death or serious injury
 Caution	CAUTION indicates a potentially hazardous situation which, if not avoided, may result in minor or moderate injury

Warning

- For safety and security of the system that is connected to the product, please read and follow this manual carefully.
- We are not responsible for any damages and safety problems due to disregards of the manual or lack of care of the product.
- Please install any extra safety circuitry or other safety materials outside the product for safety of the program that is connected to the product.
- Do not disassemble, repair or reconstruct the product. It can cause electric shock, fire, and errors.
- Since this is not explosion-proof structure, please use in a place where corrosive gas (such as harmful gas, ammonia, etc.), combustible or explosive gas does not occur.
- Do not give impact to products. It can cause of damage or malfunction.
- When you wire it, please cut out all of electric power.
- Please do not block ventilating windows. It may cause of break down.
- To avoid electric shock, please use it after installation to panel.
- Do not operate controller with wet hand, it may cause of electric shock.
- This controller is operating in 100 V – 240 V a.c, 50 – 60 Hz without additional change. If you use other voltage, it may case of fire and electric shock.
- When you put to earth, please refer to install method. But do not it earth to gas pipes, phone lines and lightning rods.
- When installing the product, please install a switch or a circuit break in order to separate the main power.

Caution

- Please avoid installing the product for following places where
 - People can touch terminal unconsciously
 - Directly exposed to the mechanical vibration or impact.
 - Exposed to the corrosive gas or combustible gas.
 - It is exposed to mechanical shock or vibration
 - Danger of corrosion or combustion of gas exist
 - Temperature changes too frequently
 - Temperature is either too high or too low
 - It is exposed to direct rays
 - It is exposed to electromagnetic waves too much
 - Humid place

- It has many combustible objects
- It has dusts and salinity
- The case of this controller is chrome–zinc plating and Bezel is made by ABS/PC anti–combustion material but please not install it to the inflammable place. Especially please do not put it on the inflammable products.
- Please keep it away from the machine or wires that can be cause of noise. Especially, please have enough warm–up when you operate it under 10 Ω temperature.
- Please install it on horizontally
- Please follow Safety Information to prevent any fire, electric shock and any damage.
- Please follow this manual for install and operation of this controller.
- Please do not turn on power until you install all of parts
- The grade of over voltage is Cataloguell and using environment is Degreell

1.3 Quality guarantee

- Unless it is included company's conditions for warrantee, we are not responsible for any warranties or guarantees.
- We are not responsible for any damages and indirect loss of the use or third person due to unpredicted natural disasters.
- The warranty for this product is valid for 1 year from purchase, and we will fix any breakdowns and faults from proper uses as it is mentioned in this manual for free.
- After the warranty period, repair will be charged according to our standard policies.
- Under following conditions, repair will be charged even during warranty period.
 - Breakdowns due to user's misuses
 - Breakdowns due to natural disasters
 - Breakdowns due to moving the product after installation.
 - Breakdowns due to modification of the product
 - Breakdowns due to power troubles
- Please call our customer service for **A/S** due to breakdowns.

2 Installation method

This is information for installation place and method of TH300/TH500 temperature and humidity program controller. So please ready it before installation.

2.1 How to install

- (1) Use the sheet plate with thickness 1 mm ~ 10 mm for panel
- (2) Push in the temperature/humidity controller starting at the front panel
- (3) Mount the product by using the fixing bracket just like an image below.
- (4) Tightening it too strongly may damage the fixing bracket or change the shape of case when mounting it to the panel by using the fixing bracket.

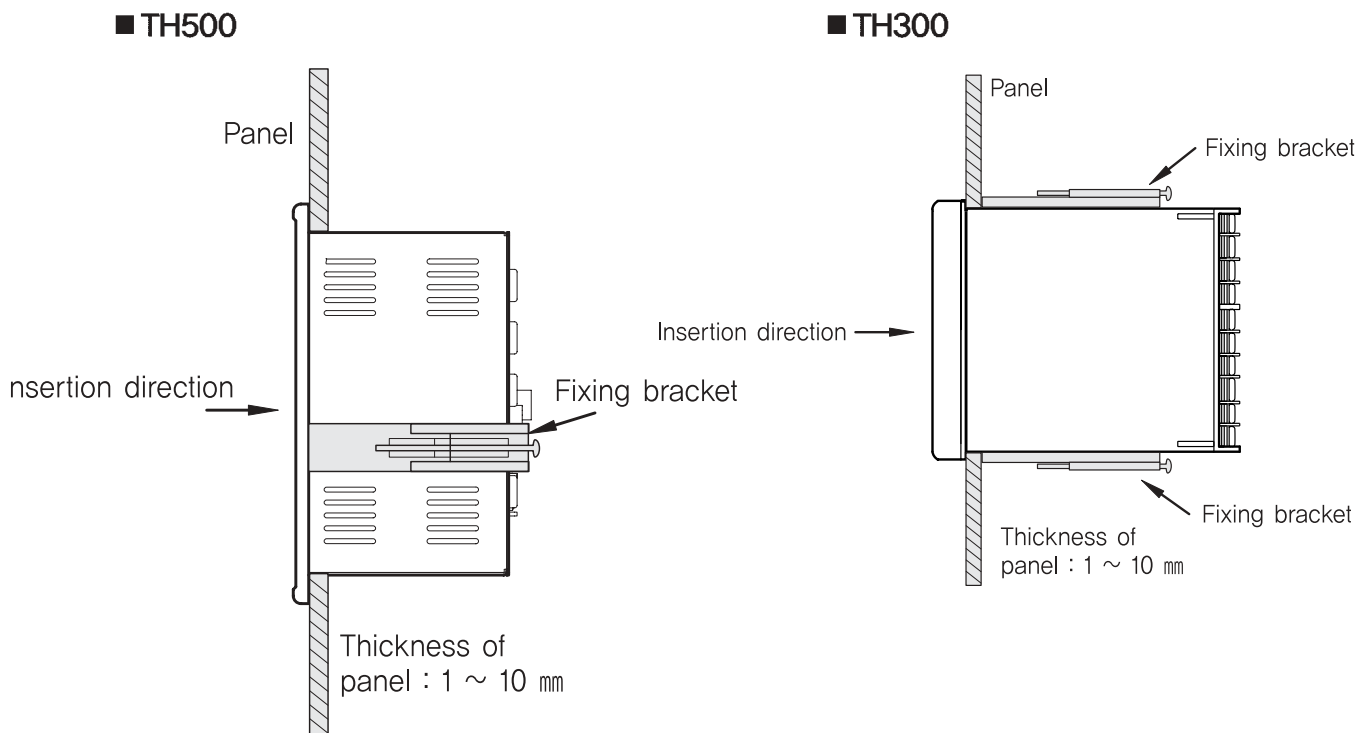

CAUTION

- To prevent electric shock, please check “turn off power”
- Before turn on power, please connect over the third class grounding.
- During retransmission, it may cause electric shock so please do not touch terminal.
- Please wire it after turn off main power
- Please contact around 2A fuse to main electronic power line.

2.2 Suffix Code

2.2.1 TH500 Suffix Code

Model	Code	Description
TH500 -	□:□:□	Programmable Temp.& Humidity Controller / 183(W)X144(H)x103(D)
TYPE	1	Standard Type * Temp. & Humidity retransmission output * Temp. & Humidity control output(SSR/SCR) * Temp. & Humidity signal input * Digital Input(D.I) : 8 points * Digital Output(D.O) : Relay 12 points, Open Collector : 8 points * Communication : RS232,RS485/422,USB
	2	Additional Type * Separate I/O Board from standard body. * Temp. & Humidity retransmission output * Temp. & Humidity signal input * Communication : RS232,RS485/422
	N	No Standard body (In case of purchasing separate I/O Board)
Separate Input · Output Board (Option)	1	Input · Output Board-1 (Relay output 12 points) Temp. & Humidity control output(SSR/SCR) D.I : 8 points, D.O : 12 points Relay Output, SMPS : 24V d.c 18 W
	2	Input · Output Board-2 (Open Collector 8 points external terminal board)
	3	Input · Output Board-3 (Relay output 8 points output board)
	4	Input · Output Board-1 + Output Board-2
	5	Input · Output Board-1 + Output Board-3
	N	No Output Board (In case of selecting standard body)
Language	N	Korean / English (Standard)
	2	English / Simple Chinese
	3	English / Traditional Chinese
	4	Korean / Simple Chinese
	5	Korean / Traditional Chinese

※ Example of Suffix Code (Standard type : TH500-1NN / Additional type : TH500-21N)

2.2.2 TH300 Suffix Code

Model	Code	Description
TH300 -	□:□	Programmable Temp.& Humidity Controller / 96(W)X96(H)x100(D)
Communication	1	RS232C
	2	RS485/422
Language	1	Korean/English
	2	English/Simple Chinese
	3	English/Traditional Chinese

2.3 Dimension and panel cutout

2.3.1. Type

●TH500-1 (Standard)

[Unit : mm]

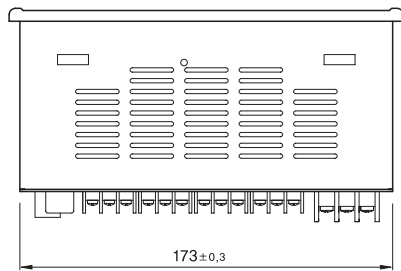
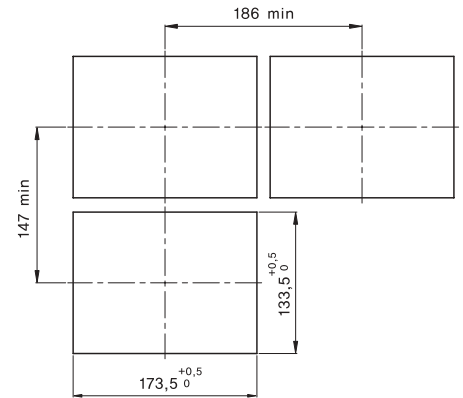
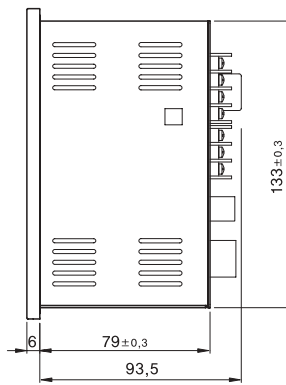
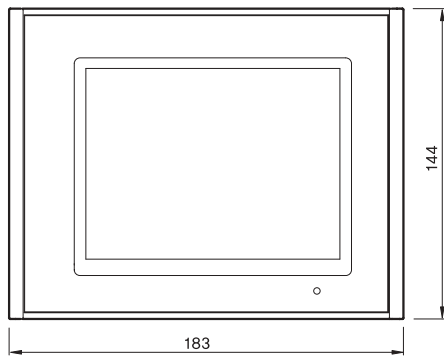

●TH500-2 (Additional)

[Unit : mm]

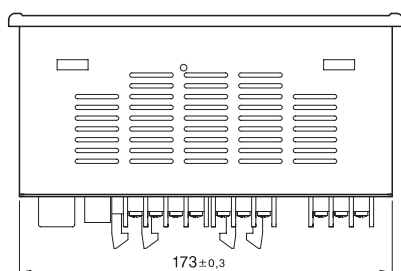
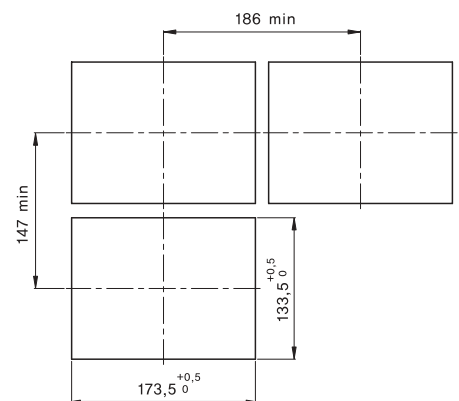
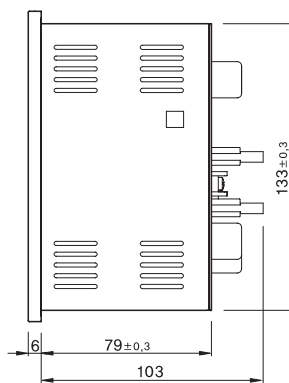
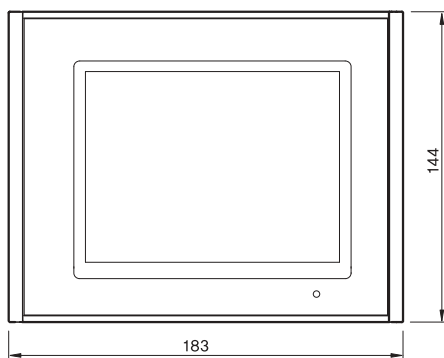

2.3.2 Separate body

● Input/Output board-1

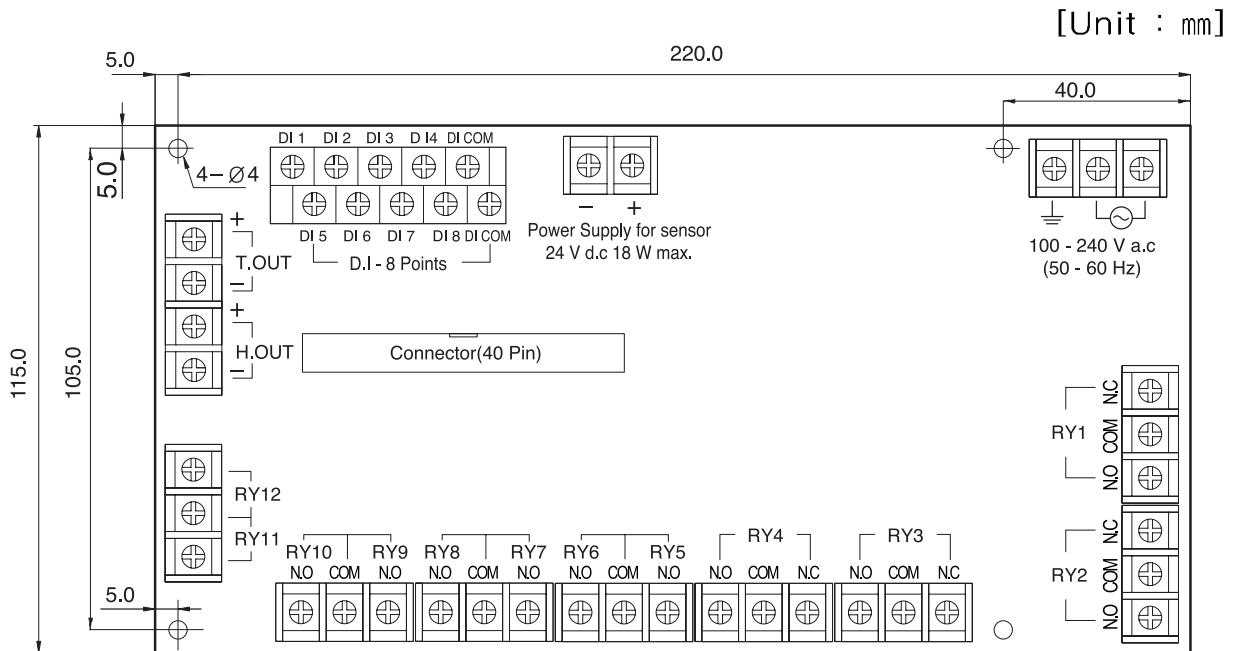

● Output board-2 (External terminal board)

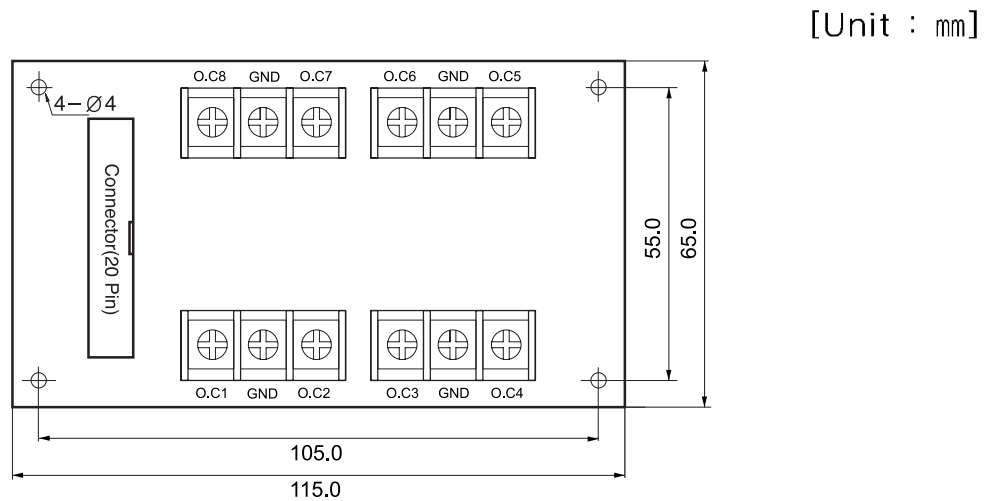

● Output board-3

[Unit : mm]

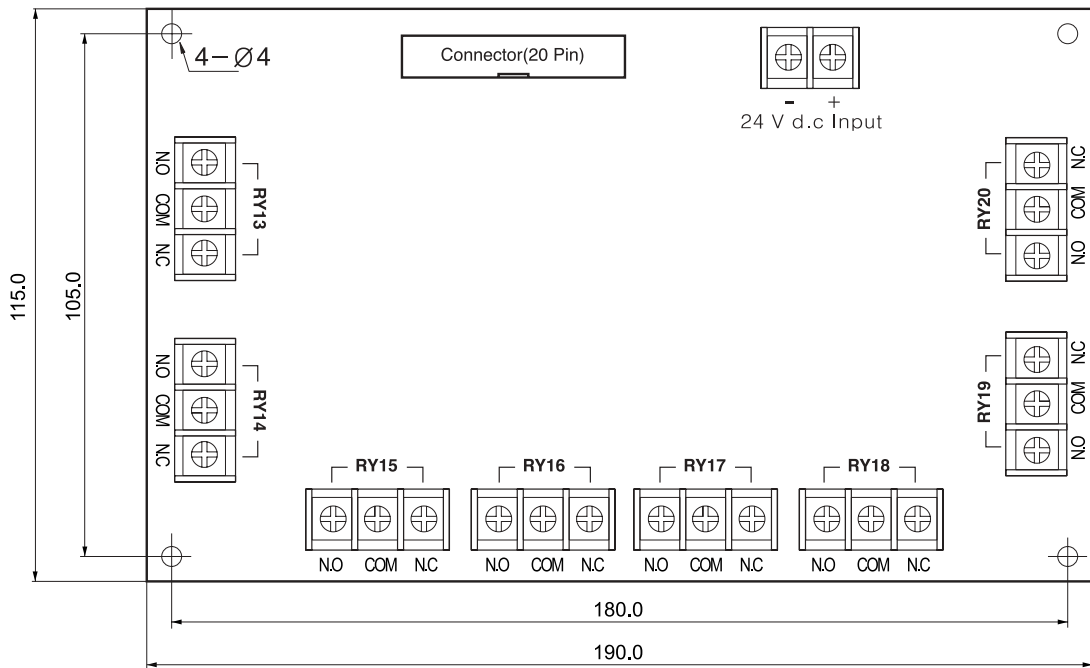

2.3.3 Standard type(TH300)

[Unit : mm]

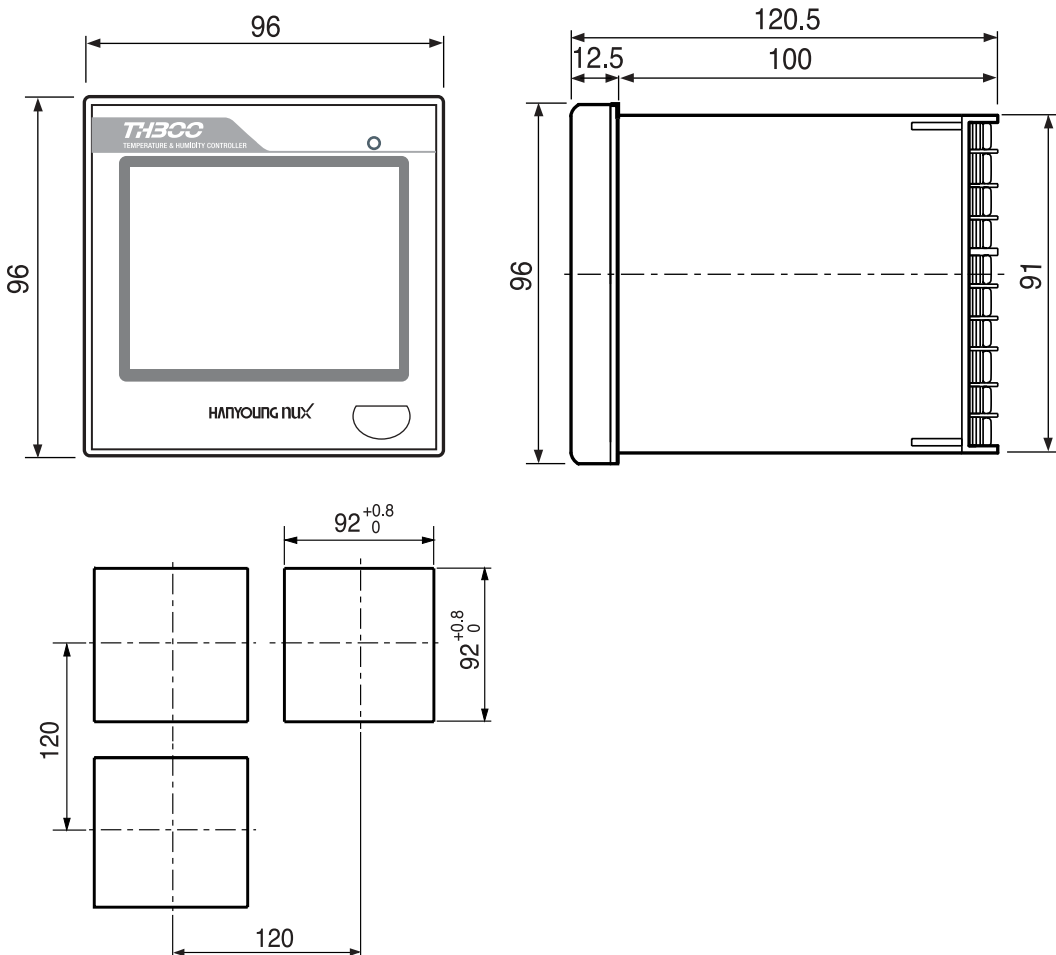

2.4 Connection Diagram

2.4.1 Model : TH500-1

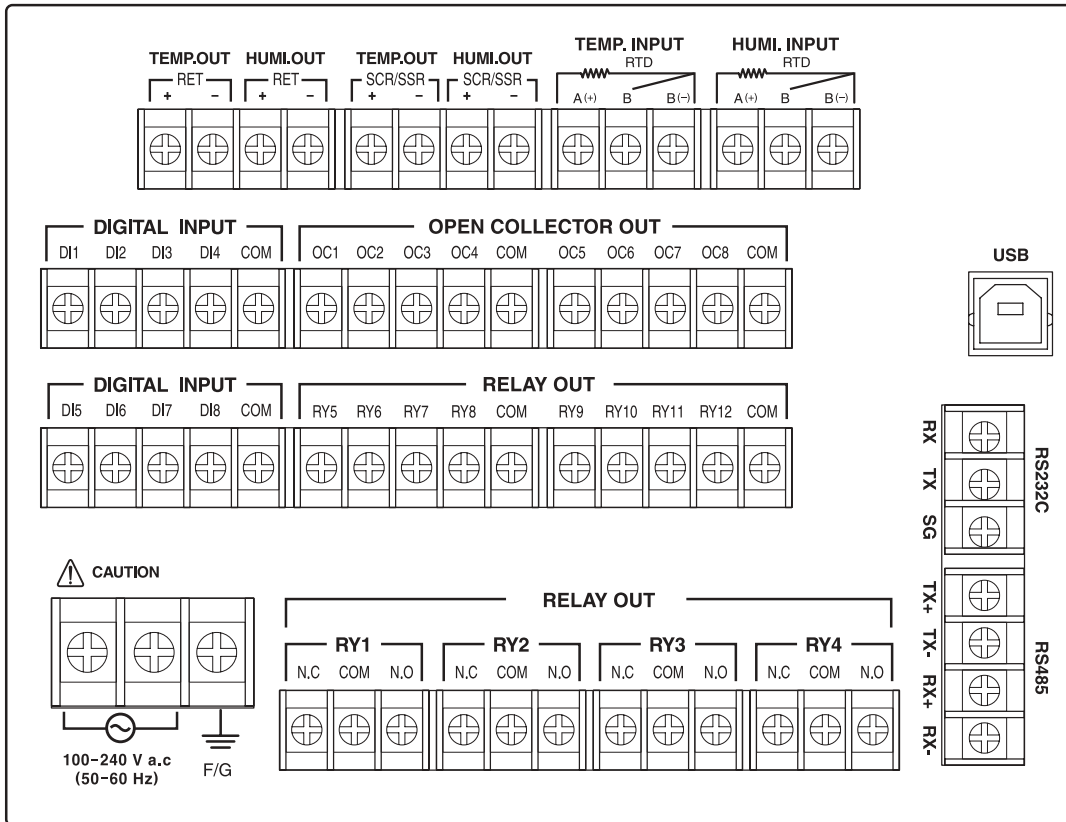

2.4.2 Model : TH500-2

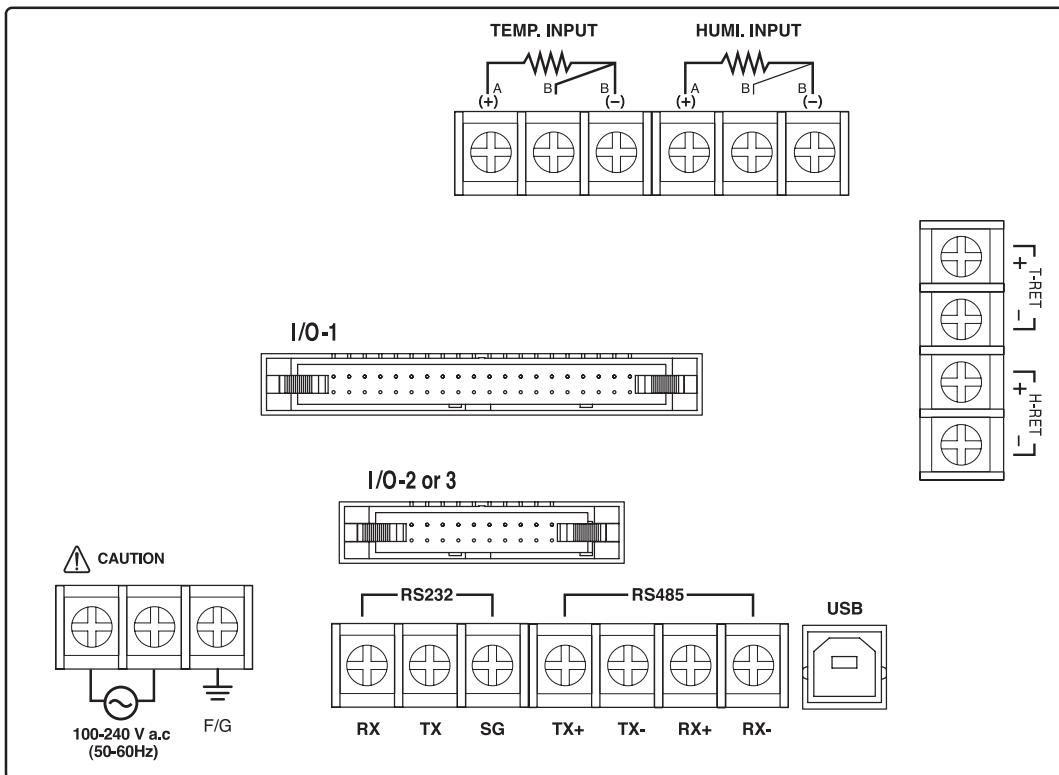

● Input/output board-1

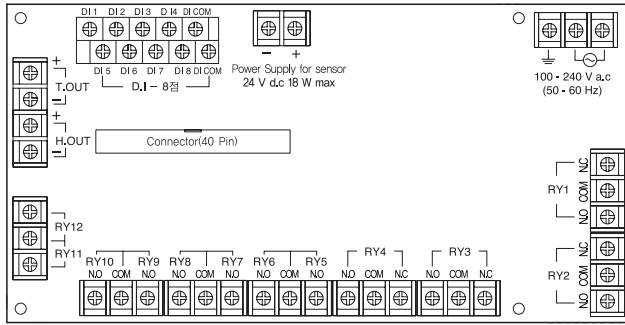

● Output board-2

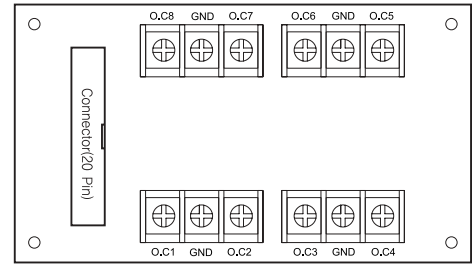

● Out put board-3

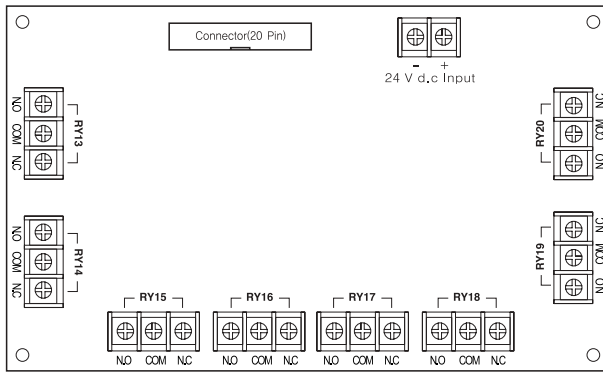

2.4.3 Model : TH300

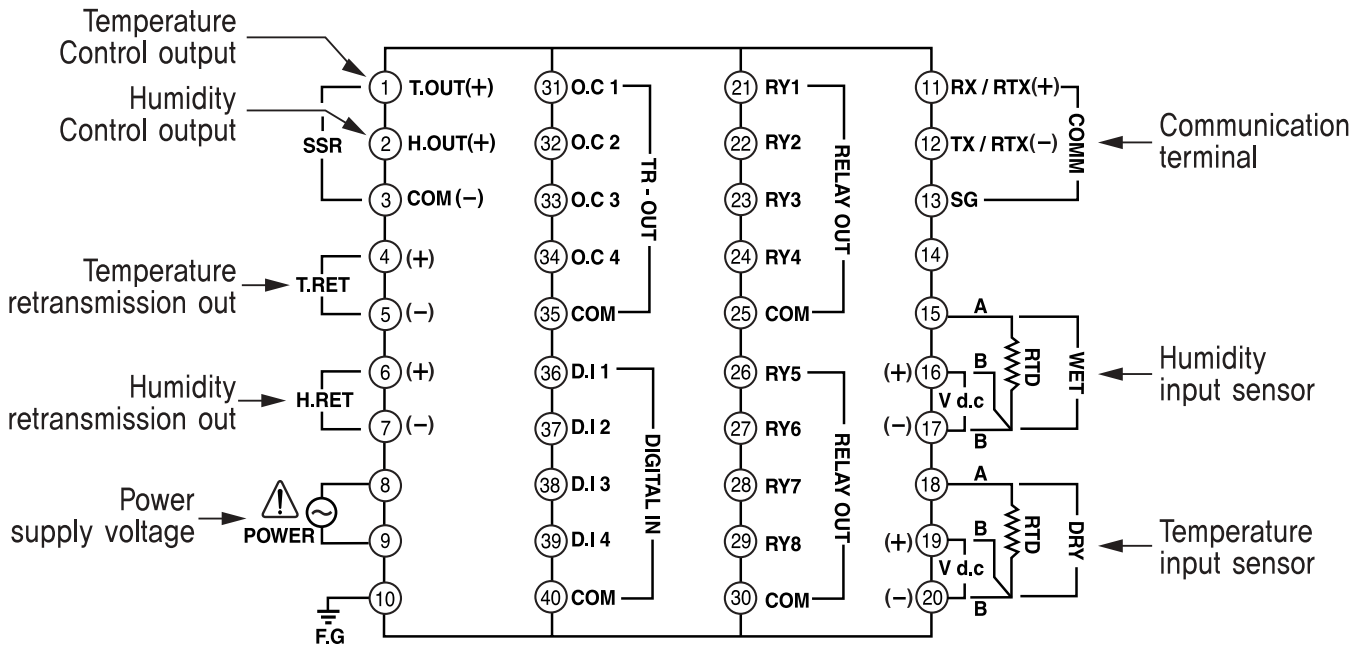

2.4.4 Connection method



- Grounding needs more than 2 mm² wire at least the 3rd class grounding connection (Grounding resistance : less than 100 Ω).
- Please use input signal wire and output wire with shield and the shield needs to have one point grounding.
- In case of R.T.D input, please connect 3 wires without resistance difference among three wires.
- Please connect Input, Output signal wire separately from power line.
- In case of current input, please attach resistance 250 Ω 0.1 % at the end of input terminals and use it accordingly.

● Sensor Input

■ RTD Input

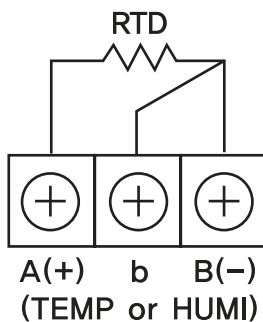

■ DC voltage input

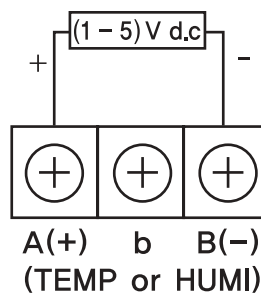

■ DC current input

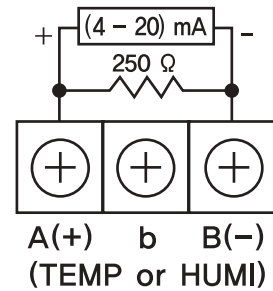

● Connection of Temp / Humidity control output and retransmission output

■ Connection of Temp / Humidity control output

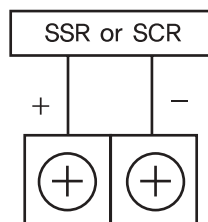

■ Temp / Humidity retransmission output

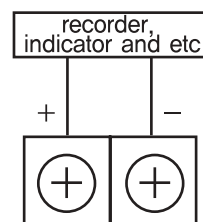

● Digital output (D.O)

■ Relay output (1c Contact) – ※ Only with TH500.

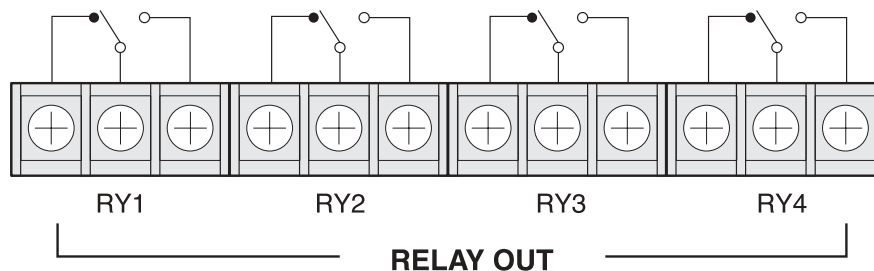

■ Relay output (1a Contact)

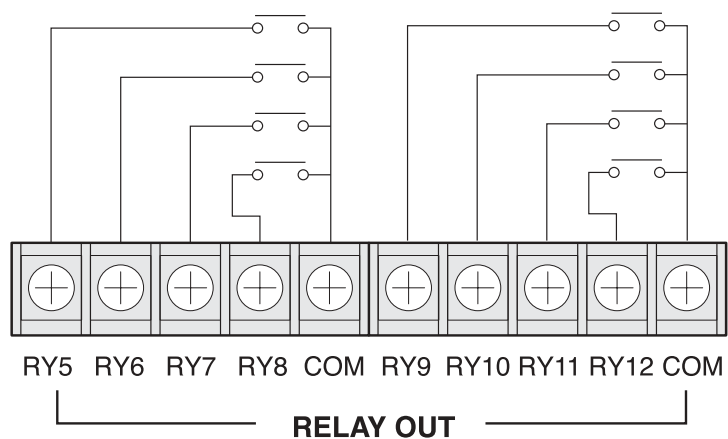

■ Transistor output (With TH300 D.O : 1 ~ 4)

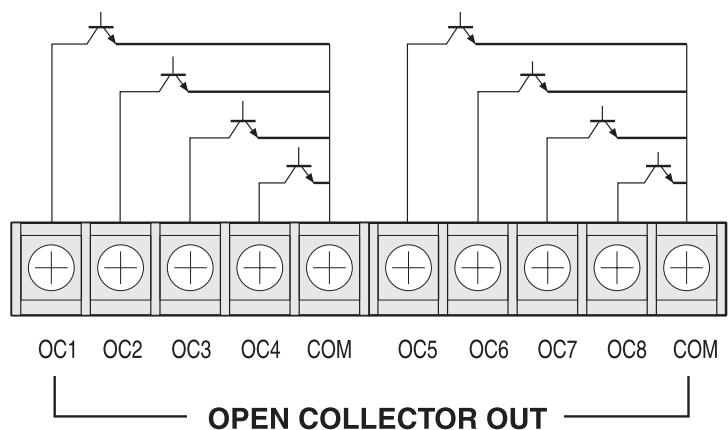

2.4.5 Digital Input (D.I)

When using open collector, please use as follows : Voltage of both ends should be below 2 V and leakage current should be below 100 μ A.

- Relay input (D.I of TH300 D.I: 1 ~ 4)

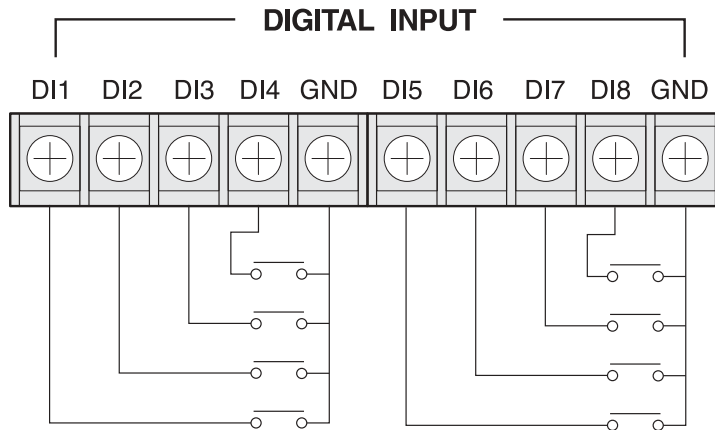

- Transistor input (D.I of TH300 D.I: 1 ~ 4)

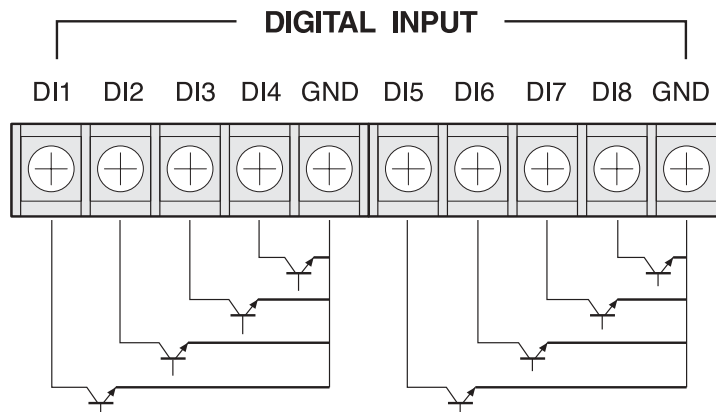

2.5 Communtcation connection

2.5.1 RS232C Connection(base on 9pin connector)

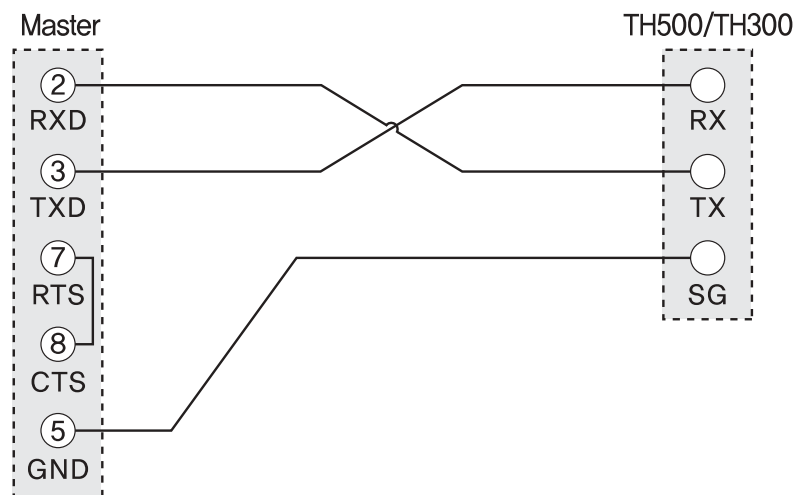

2.5.2 RS422/RS485 arrangement

maximum 32 machines. Please contact Terminating Resistance (100 ~ 200 Ω 1/4 W) to the both of ends for retransmission lines.

- 2 Wire connection

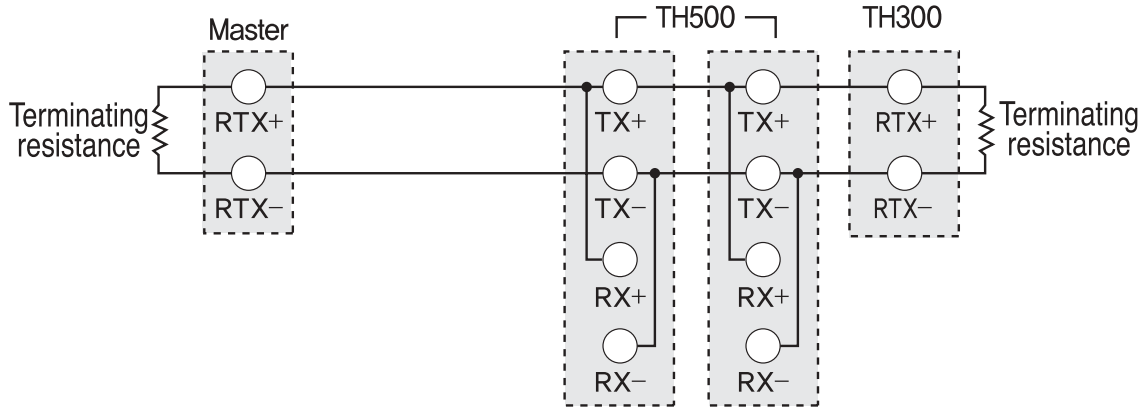

- 4 Wire connection

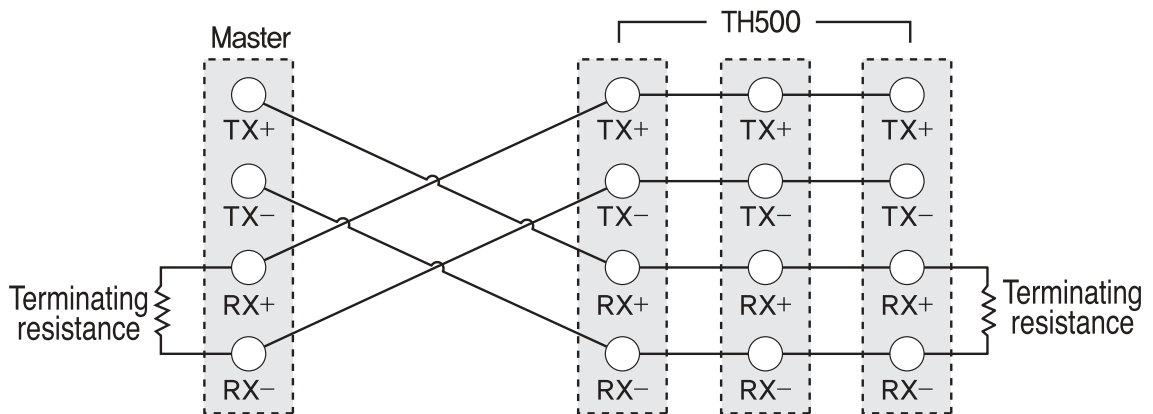

3. Setting and Operating

3.1 Initial screen

When supplying the power in after completing the installation, operating screen will be displayed after the Logo display [FIG.1] screen and check [FIG.2] screen are displayed sequentially. (Users can edit the logo display screen and system check screen)

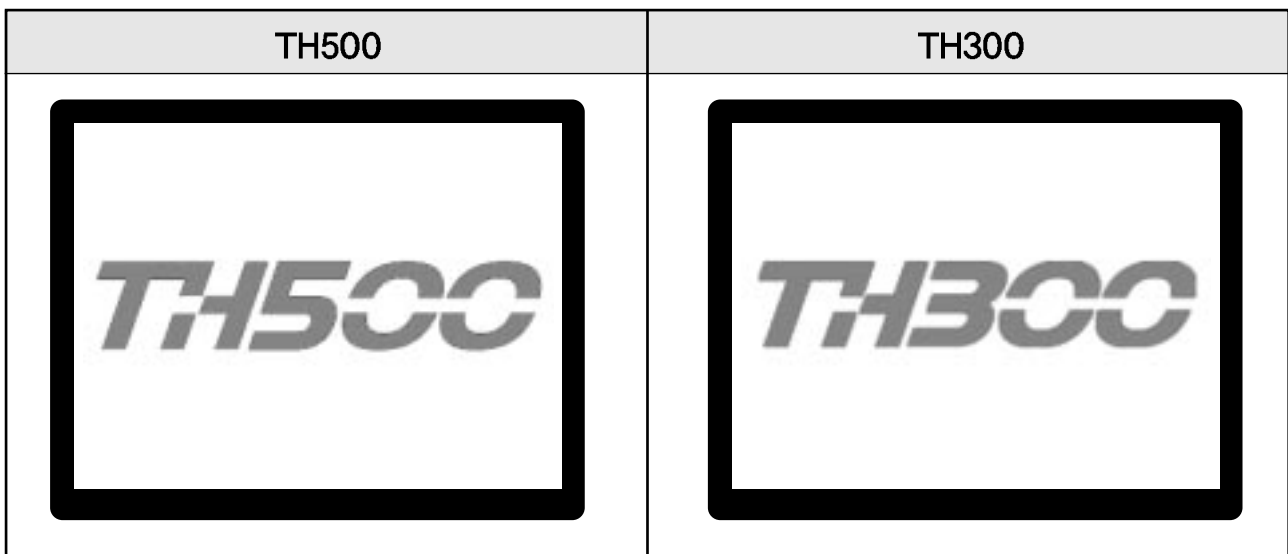

[FIG.1] Logo display

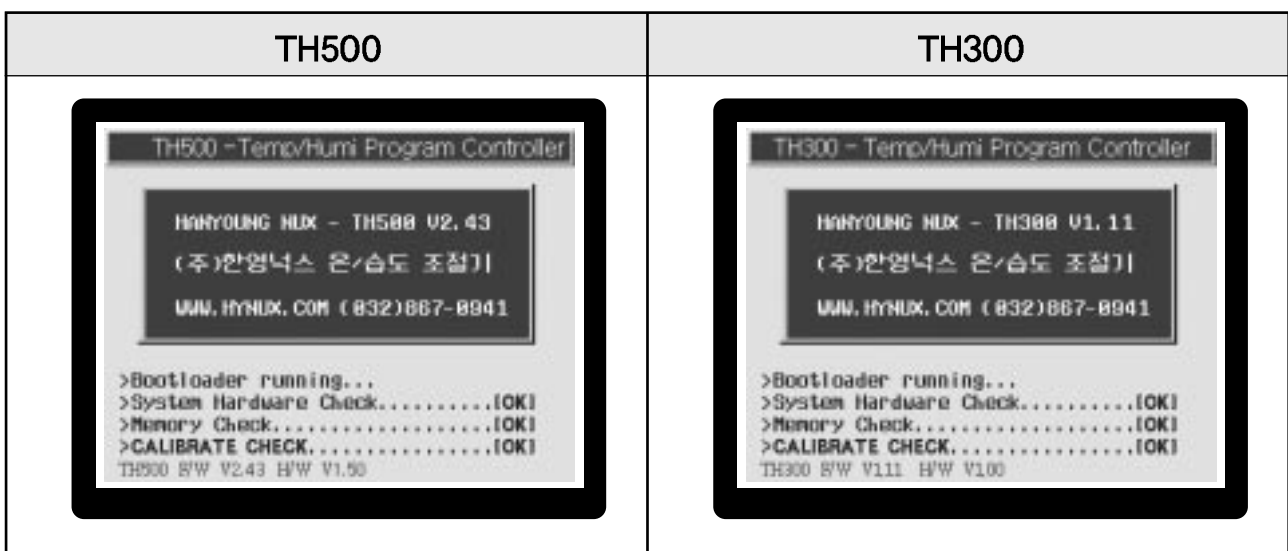



[FIG.2] System check

3.2 How to input

Basic setting button and input screen has the function as [Figure 1]. Input screen which is able to set necessary data on each screen will be displayed..

● [Figure 1] Setting button and Input screen

Button	Name	Function
	Select button	Users can select this button on their demand. If you press this button, its color will turn into another. By releasing it back, you can select this button operation.
	Active input box (Input available)	Users can enter various set values into this box as they wish. When you press the box, a certain range of numbers or the text input box [Fig.4 to Fig.7] will appear depending on situations. Then, you have only to press the set value.
	Inactive input box (Input unavailable)	This box is inactive under current conditions or situations. However, if you put it under certain conditions or situations, it will turn into the active input box as shown above.

3.2.1 Screen for button Input

The Fig. 3 is the basic number input box. You can enter integral numbers or real numbers (decimal point) there. The title of an entered number and its upper and lower limits will be indicated on the left top of the box. The current input value will be indicated at the indication box over the figure board. The entered number will be entered completely only if you enter the **ENT** key. You can cancel the entered content by pressing the **ESC** key.

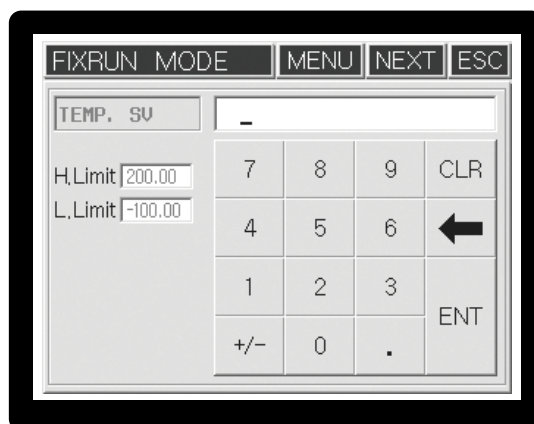

[Fig.3] is the basic number input box

3.2.2 Number / Korean / English / sign Input

Fig. 4 to 7 shows the screen for entering the Number/Korean/English/Sign. This multi-input screen enables you to enter the Number/Korean/English/Sign text respectively by pressing the **CHANGE KEYPAD** in turn. Its shift order is **NUMERIC** → **한글입력모드** → **ENGLISH** → **SYMBOL**. You can return to the **NUMERIC** by pressing the **CHANGE KEYPAD**. The arrangements of Number/Korean/English/Sign keyboards are different from each other. However, the Function keys on the right side play the same roles as follows.

Button	Information
CLR	Delete all the current texts entered.
←	Delete one letter ahead of the current cursor.
ENT	Save the text indicated up to the current cursor into the internal memory.

After typing the text based on the combination of keys and functions, you can save all the texts completely by pressing the **ENT** key. As they save completely, you will be also escaped from the multi input screen. If you are to cancel the text, you can press the **ESC** key on the right top side. By doing so, you can delete all the current text while escaping the input box.

When pressing **MENU** in the upper part of initial screen → **PROGRAM** → **Program operation setting** → **PTN_NAME 001** Number input screen [Fig.4] is going to be displayed. Set up by displaying the input screen of number, Korean, English, and, symbol with using the **CHANGE KEYPAD**.

3.2.3 Number Input Mode

The screen for number input is shown in the [Fig.4]. If you press the number **0** ~ **9** and **.** keys once, they will be indicated on the cursor position. Whenever you press the **([)] ° % × ÷ + -** keys on the left side of the keyboard, they will be indicated in turn. When you press such duplicate keys, the cursor will not move at all while waiting for continuous entry. At that time, if a certain period of time (approx. 1 second) passes, the cursor will move automatically to the next position disabling you from continuous entry.

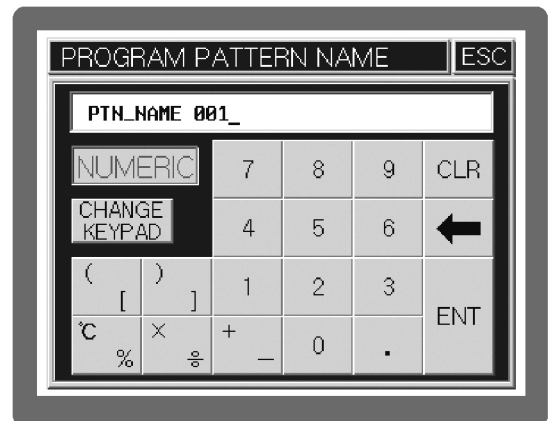

[Fig.4] The screen for number input

Ex) If you want to indicate 1. (The _ on the bottom indicates a flickering cursor.)

- Operation:
- Result : 1_

Ex) If you want to indicate 123.45. (The _ on the bottom indicates a flickering cursor.)

- Operation: + + + + +
- Result: 123.45_

Ex) If you want to indicate [.

- Operation: + (Press twice within one second.)
- Result: [_ (The _ on the bottom indicates a flickering cursor.)
- Operation: One second passed after the key is pressed once.
- Result:) _ (The _ on the bottom indicates a flickering cursor.)

3.2.4 Korean Input Mode

The screen for Korean input is shown on the Fig. 5. All the keys except the , , , keys consist of duplicate keys. There is also an additional function key . The principle of using function keys is the same in every mode. If you want to enter double consonants such as ㄲ, ㅋ, ㆁ, ㄷ, ㅌ, ㄴ, ㄹ, ㄺ, ㄻ, ㄼ, you should press the consonant three times. You should press the key, if you go to the next letter while entering letters.



[Fig. 5] The screen for Korean input

Or you can also use such key when entering the blank. The Korean alphabet consists of three elements such as an initial consonant, a medial vowel and a final consonant. This input mode is classified into consonants and vowels, so the consonants are not divided into an initial and final one. Therefore, you have only to enter an appropriate consonant regardless of its initial or final position. The medial vowel consists of vowels only, so you have only to press an appropriate vowel.





Ex) If you want to indicate “ㄱ”.

- Operation: +
- Result: ㄱ _ (The _ on the bottom indicates a flickering cursor.)

Ex) If you want to indicate “ㅋ”.

- Operation: + +
- Result: ㅋ _ (The _ on the bottom indicates a flickering cursor.)





Ex) If you want to indicate “ㄱ”.

- Operation:  +  +  + 
- Result: ㄱ_ (The _ on the bottom indicates a flickering cursor.)





Ex) If you want to indicate “가”.

- Operation:  +  + 
- Result: 가_ (The _ on the bottom indicates a flickering cursor.)















Ex) If you want to indicate “의”.

- Operation:  +  +  + 
- Result: 의_ (The _ on the bottom indicates a flickering cursor.)















Ex) If you want to indicate “각”.

- Operation:  +  +  + 
- Result: 각_ (The _ on the bottom indicates a flickering cursor.)



Ex) If you want to indicate “한영닉스”.

- Operation:  +  +  +  +  +  +  +  +  +  +  +  +  + 
- Result: 한영닉스_ (The _ on the bottom indicates a flickering cursor.)

Ex) If you want to indicate “대한민국”.

- Operation:  +  +  +  +  +  +  +  +  +  +  +  +  +  + 
- Result: 대한민국_ (The _ on the bottom indicates a flickering cursor.)

3.25 English Input Mode

The screen for English input is shown on the Fig. 6. All the keys except the  and  keys consist of duplicate keys. Its basic use is the same as that of the Korean input mode.

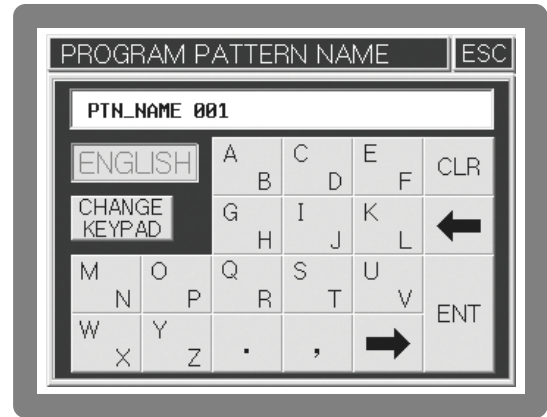

[Fig. 6] The screen for English input

Ex) If you want to indicate "B".

- Operation:  + 
- Result: B _ (The _ on the bottom indicates a flickering cursor.)

Ex) If you want to indicate "OPER"

- Operation:  + Wait for one second +  +  +  +  + 
- Result: OPER _ (The _ on the bottom indicates a flickering cursor.)

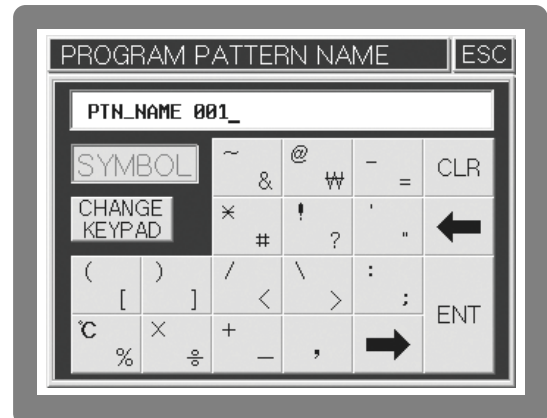

3.26 Sign Input Mode

The screen for sign input is shown on the Fig. 7. All the keys except the  key consist of duplicate keys. Its basic use is the same as that of the English input mode.























[Fig. 7] The screen for sign input

Ex) If you want to indicate "&".

- Operation:  + 
- Result: & _ (The _ on the bottom indicates a flickering cursor.)

Ex) If you want to indicate "([1+2] X 3) = 9 °C".

- Operation:  + Wait for one second +  +  +  +  +  +  +  +  +  +  +  +  +  +  +  +  +  +  + 
- Result: ([1 + 2] X 3) = 9 °C _ (The _ on the bottom indicates a flickering cursor.)

3.3 The name of each part on the operating screen

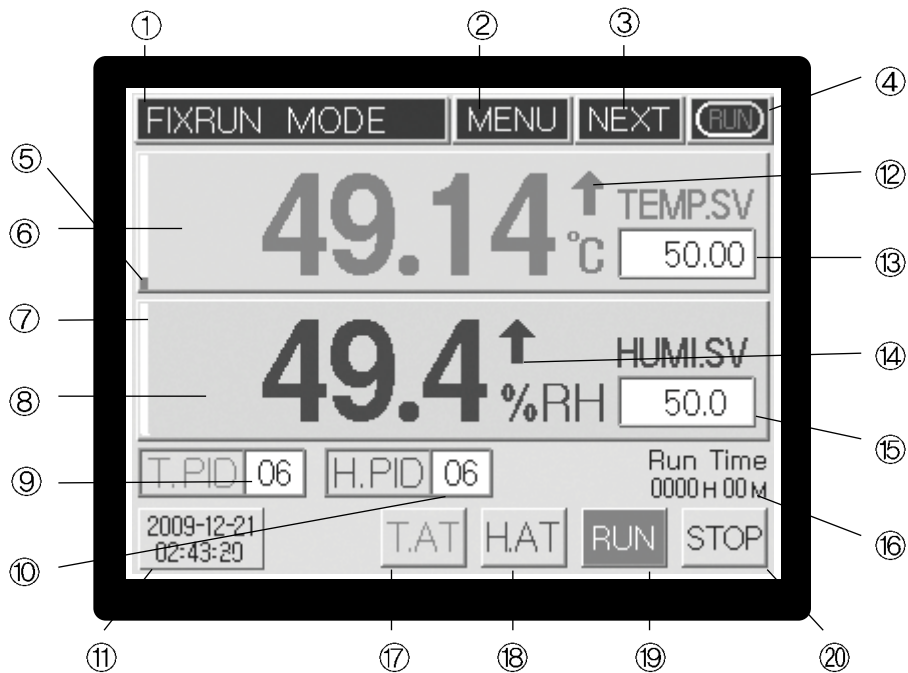

[Fig. 8] Operation screen 1 for fixed control

NO	Name	NO	Name
①	Current operation status	⑪	Current date/time
②	Menu button	⑫	Temperature PV Up/Down indication
③	Operation screen 2 shift button	⑬	Temperature SV input box
④	Running/Stop indication	⑭	Humidity PV Up/ Down indication
⑤	Control output BAR for currenttemperature (MV)	⑮	Humidity SV input box
⑥	Current temperature PV	⑯	Running time indication
⑦	Control output BAR for currenthumidity (MV)	⑰	Temperature A/T button
⑧	Current humidity PV	⑱	Humidity A/T button
⑨	Temperature PID Zone No. input box	⑲	Start button for Fix-Running
⑩	Humidity PID Zone No. input box	⑳	Stop button for Fix-Running

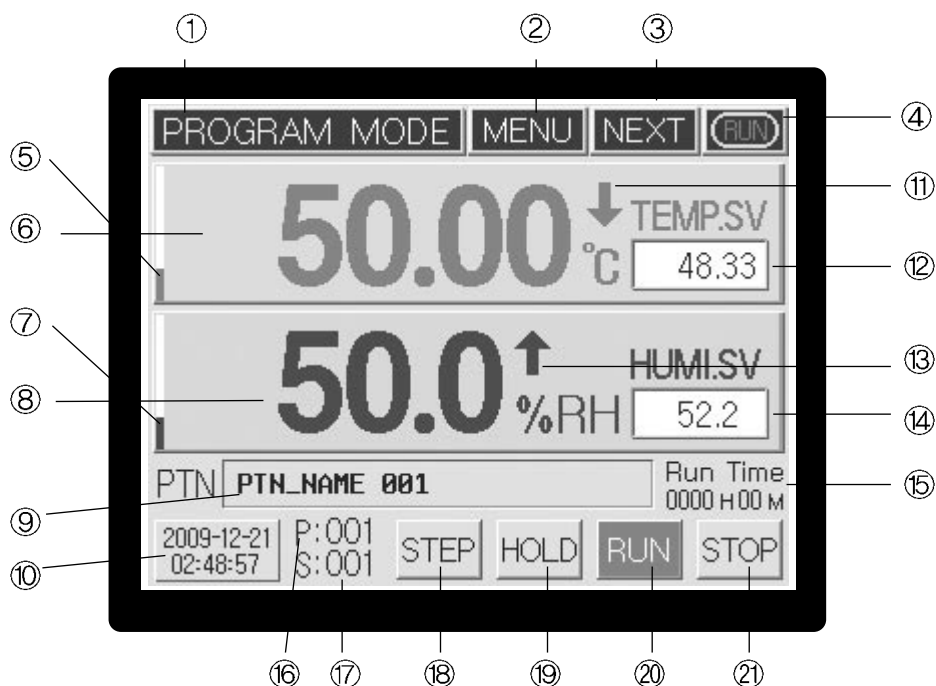

[Fig. 9] Operation screen 1 for program control

NO	Name	NO	Name
①	Current operation status	⑬	Humidity SV Up/Down indication
②	Menu button	⑭	Start segment No. input box (When operation stops, it starts within the pattern (segment input unit))
③	Operation screen 2 shift button		
④	Running/Stop indication	⑮	Running time indication
⑤	Control output BAR for current temperature (MV)	⑯	Current operating pattern No.
⑥	Current temperature PV	⑰	Current operating segment No.
⑦	Control output BAR for current humidity (MV)	⑱	Program STEP button
⑧	Current humidity PV	⑲	Program HOLD button
⑨	Operation pattern name	⑳	Program operation Start button
⑩	Current date/time	㉑	Program operation End button
⑪	Temperature SV Up/Down indication	※ (16)~(19) displayed only during operation	
⑫	Start pattern No. input box(When operation stops, it either display the pattern number or used as input unit.)		

The operation screen 1 [Fig. 8, Fig. 9] is the basic screen where you can enter either temperature & humidity setting value (SV) or start pattern/loop No. in the Fix/Program mode. After entering your desired setting value, you can press the **RUN** button to start controlling.



After pressing the **RUN** button, you are unable to press various setting buttons like MENU or input boxes, because they may have a serious effect on system controlling operations.

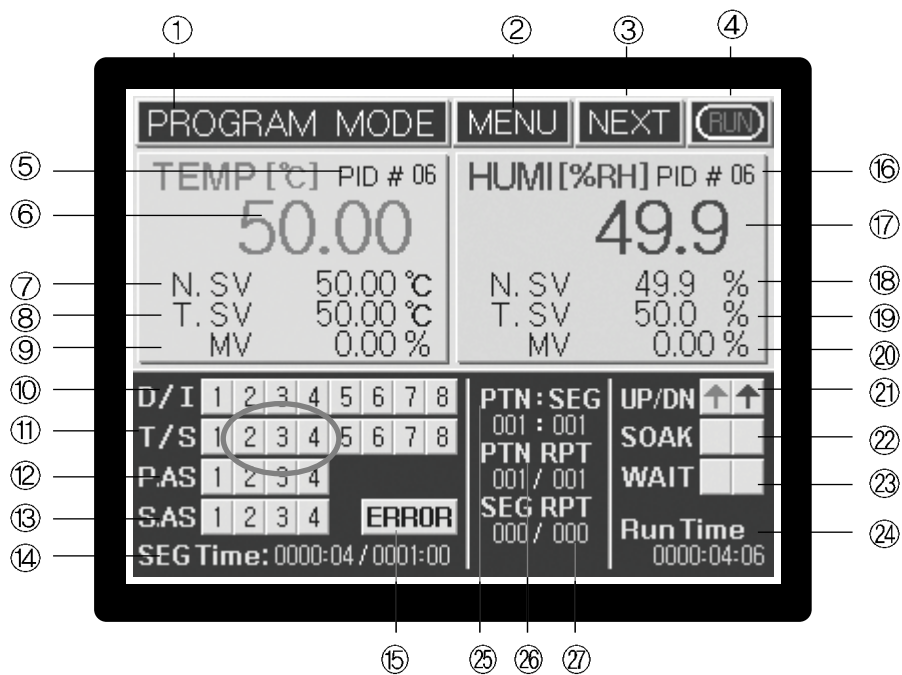

[Fig.10] Operation screen 2 for program control

NO	Name	NO	Name	NO	Name
①	Current operation status	⑪	T/S status indication *I/S status indication	⑳	Temperature/humidity up/down interval indication
②	Menu button Operation screen 3	⑫	Pattern Alarm Status Indication *T.ON, H.ON status indication	㉑	Temperature/humidity maintain indication
③	shift button 1	⑬	System Alarm Status Indication *Delay (D/S)/multiplication (DR) signal status indication	㉒	Temperature/humidity standby (Wait) indication
④	Running/Stop indication	⑭	SEG operation time indication	㉓	Total operation time (Run time)
⑤	Temperature PID ZONE No.	⑮	System error indication button	㉔	Pattern number/segment number indication
⑥	Current temperature PV	⑯	Humidity PID zone number	㉕	Pattern repetition indication, Number of sequence, /Number of repetition setting
⑦	Current temperature SV	⑰	Current humidity process value (PV)		
⑧	Target Temperature Set Value(TSV)	⑱	Current humidity set value (SV)	㉖	Segment repetition indication, Number of sequence, / Number of repetition setting
⑨	Controlling output amount of current temperature (MV)	⑲	Target humidity set value (TSV)		
⑩	D/I status indication	㉑	Current humidity control output amount (MV)		

※ * Displaying items are displayed when pressing the () which located on the left-bottom of the screen.

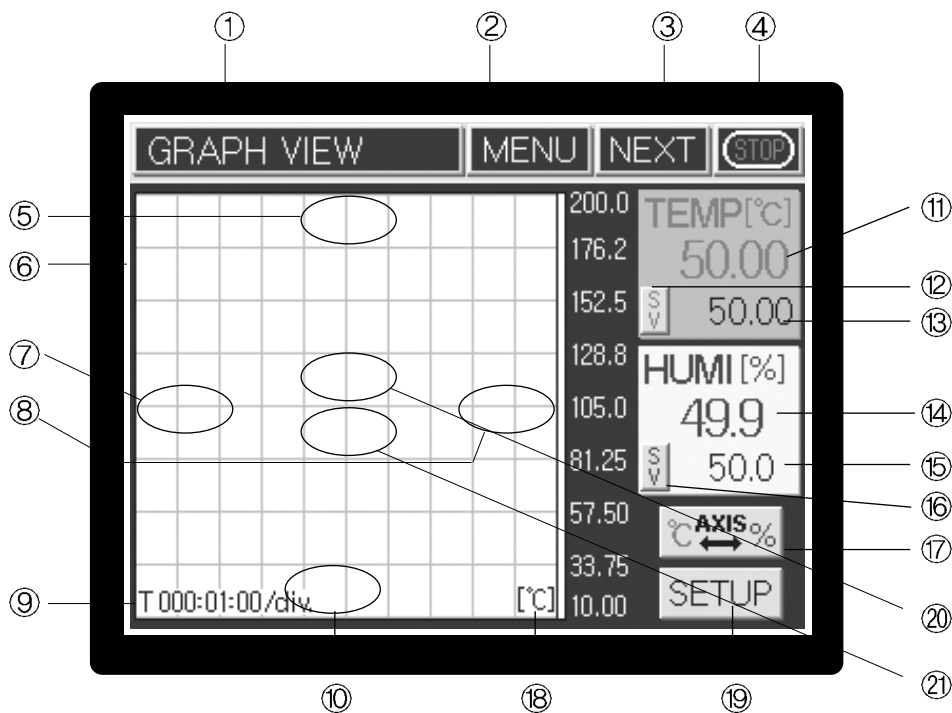

[Fig.11] Screen for graph indication

NO	Name	NO	Name
①	Current operation status	⑫	Current temperature MV/SV indicator shift button
②	Menu button	⑬	Current temperature MV or SV indication
③	Operation screen 1 shift button	⑭	Current humidity PV indication
④	Running/Stop indication	⑮	Current humidity MV or SV indication
⑤	Upside screen of Y axis	⑯	Current humidity MV/SV indicator shift button
⑥	Temperature & humidity SV, PV indication	⑰	Y axis temperature & humidity unit shift button
⑦	Div time increase of X axis	⑱	Y axis unit indication
⑧	Div time decrease of X axis	⑲	Graph/Save setting button
⑨	X axis time / Div	⑳	Screen ZOOM IN
⑩	Low part screen of Y axis	㉑	Screen ZOOM OUT
⑪	Current temperature PV indication		

3.4 Running of Fix-control

Fix-control is running a temperature and humidity by fixed set value (SV).

3.4.1 Running selection of Fix-control 1.

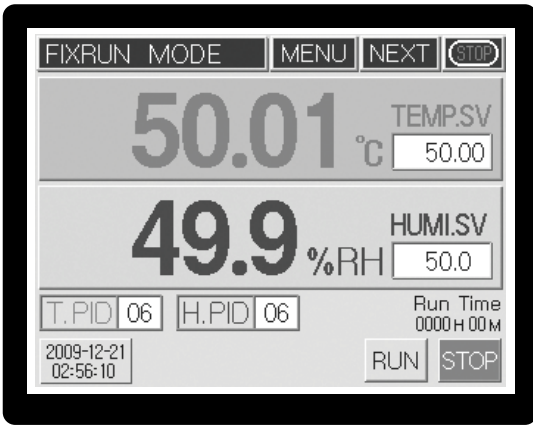

[Fig.12] Running stopped screen 1 for Fix control

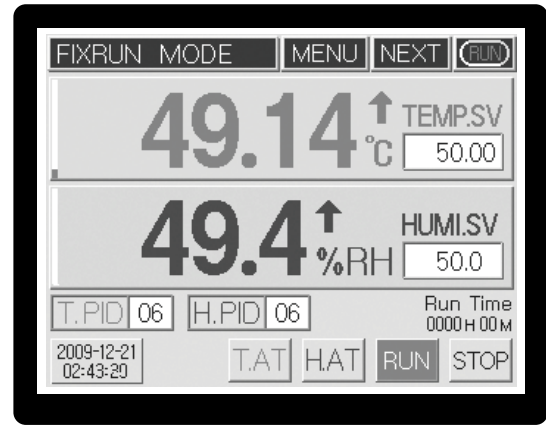

[Fig.13] Running screen 1 for Fix control

Operation start: [FIG.12] Input the temperature set value (temperature SV) and humidity set value (humidity SV) within the fix control operation stop status screen and press the **RUN** button then the fix control operation will be started just like a [FIG.13]. Here, **STOP** button on the upper right side will be changed to **RUN** and **RUN** button on the lower right side will be displayed with the red color.

Operation stop: Press the **STOP** button on the lower right side to stop the operation. ("Stop the system control" will be displayed). Here, press **YES** to stop the operation

When selecting the fix control or program control, press the **MENU** button within the fix control operation stop [FIG12] screen then function setting screen will be displayed. Within this screen, press the **FUNC. SET** button to select the operation method of function setup : screen. Pressing the **FIXRUN** button will select the fix control. Set each of setting lists in the operation setting screen 2 by pressing the **NEXT** button.

While performing the fix control, changing the set value (SV) will automatically change the PID ZONE applying number in accordance with the set value. If users want to use the specific PID zone, please input the PID zone number after inputting the set value. During operation, if **T.A.T** and **H.A.T** button appear on the lower side of fix control operation screen, each of these refers to temperature and humidity auto tuning button. Auto-tuning is operated only in the fix control operation mode and it runs the auto-tuning by pressing the button after inputting the temperature and humidity set value.

In case where users need to stop the auto-tuning, please press the **T.A.T** (temperature side auto-tuning button) or **H.A.T** (humidity auto-tuning button). Obviously pressing the fix control button will **STOP** the control operation and auto-tuning.

During auto-tuning, all of the computing values corresponding to the auto-tuning will not be saved if users stop the auto-tuning while it is operating. Auto-tuning can be operated up to 24 hours and elapsing the indicated hours will stop the auto-tuning.



- When it comes to temperature, its PV will be always displayed unless the sensor line is disconnected. However, as far as humidity is concerned, its PV will not be indicated unless a setting value (SV) is entered. If you set the SV to 0 and press the **RUN** button, you can control the temperature only.
- It is impossible to execute A/T for temperature and humidity at the same time. Therefore, it is desirable to try tuning humidity while maintaining a target temperature. The button concerned will turn on and off during tuning.

Auto Tuning button : When pressing **MENU** button in the running screen of Fixing Control, function setting menu will be displayed. After pressing left-top button and pressing password, System Setup screen will be displayed, Once again if you press [Sensor Input Setup], Sensor Input Setup screen 1 will be displayed. Press **NEXT** button and Auto Tuning will be shown on A/T button indication in the Sensor Input Setup 4.

T.AT	Temperature Auto Tuning button (Turn on and off during running)
H.AT	Humidity Auto Tuning button (Turn on and off during running)

3.4.2 Running selection of Fix-control 2.

Process value and Set value of temperature and humidity is shown basically in the running screen 2 for fix control. There is shown also for Inner signal(I/S), Time signal(T/S), Digital input signal(D/I), Alarm signal(A/S), and indicate a gradient of initial set value by form of UP/DN and SOAK.

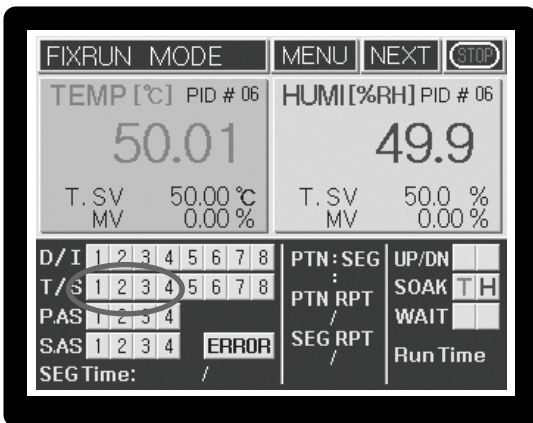

[Fig.14] Running stopped screen 2 for Fix control.

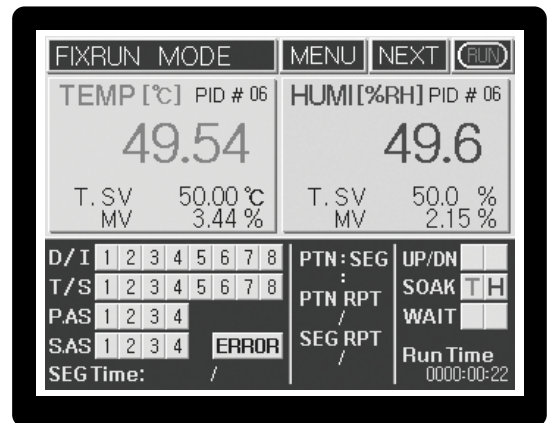

[Fig.15] Running screen 2 for Fix control

※ Pressing the indicated circle in the [Fig.14] will change the display unit

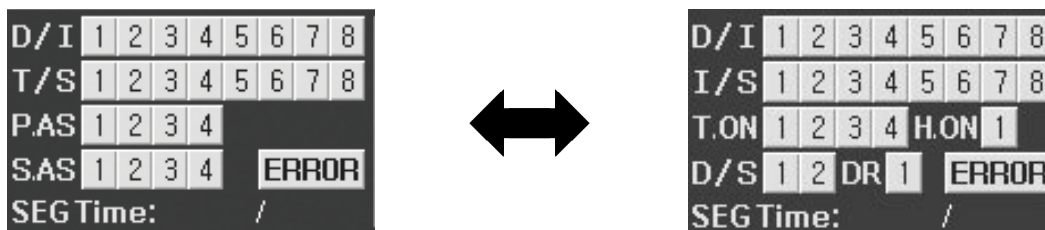

3.5 Running of Program control

Program control is control a Process Value (PV) by change of Set Value (SV) according to course of time. For example, it is increase the current temperature to 30 °C for 10 min. and maintain the 30 °C for 15 min., and then increase to 70 °C again for 40 min. and maintain the 70 °C for 1 hour. Program control is especially using widely in the test equipment for environment like as thermostat and electric furnace.

3.5.1 Selection of Program Control Running.

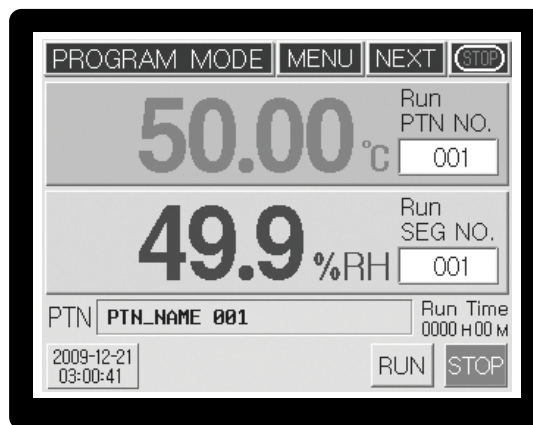





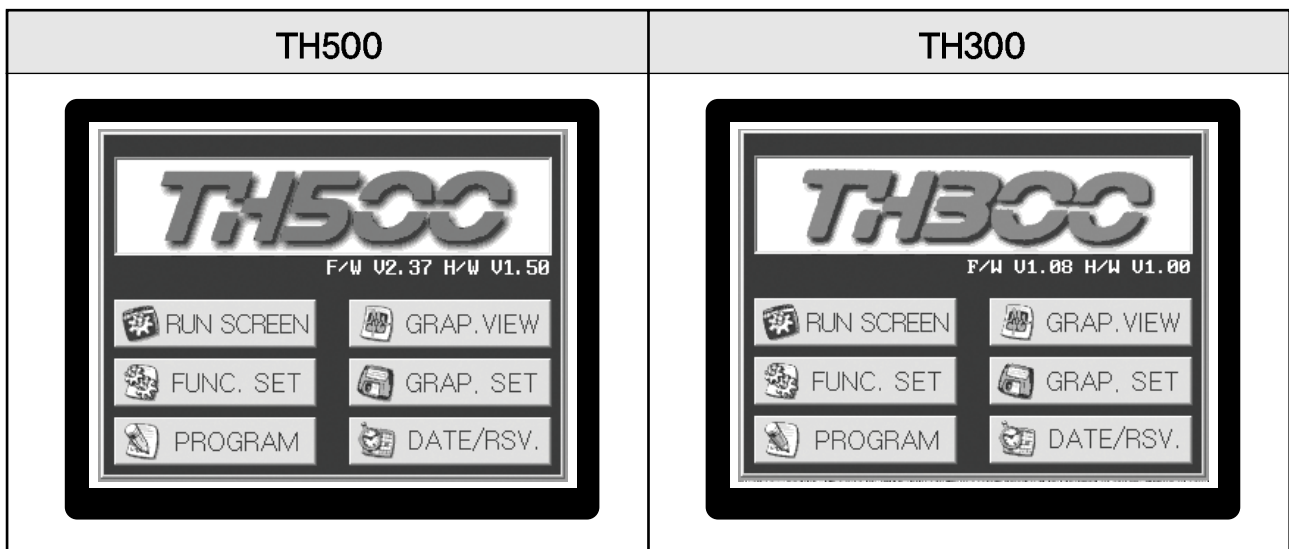

[Fig.16] Running stopped screen 1 for program control.

In order to running with program control, press the **MENU** button of the top on the running stopped screen 1 for program control [Fig.16] and move to the screen for function setting [Fig.17].



[FIG.17] Function setting menu

Move to the screen for "Function setup 1" with press the

 button, and select the program control as running method with press the  button. After finish to setting for function setup 1 ~ 2 with press the  button, and move to "Function setting menu" screen with press the  button. And then, finish the set for , , and move to the Program Set Screen [Fig.18]

3.5.2 Set of Program Control Pattern

Press the  button in the program set screen [Fig.18] and move to the screen for program pattern set [Fig.19]. Establish the set item for each segment of pattern in the screen for program pattern set [Fig.19].

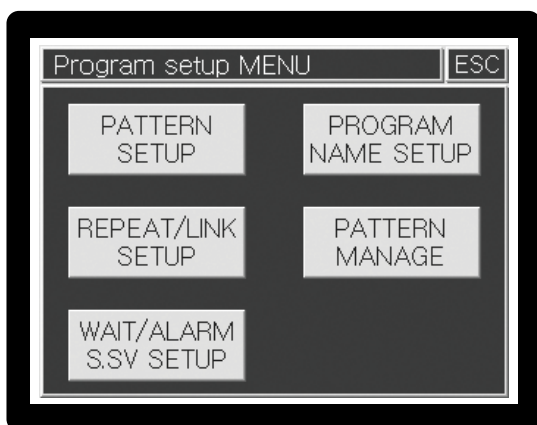

[Fig.18] Program Set Screen

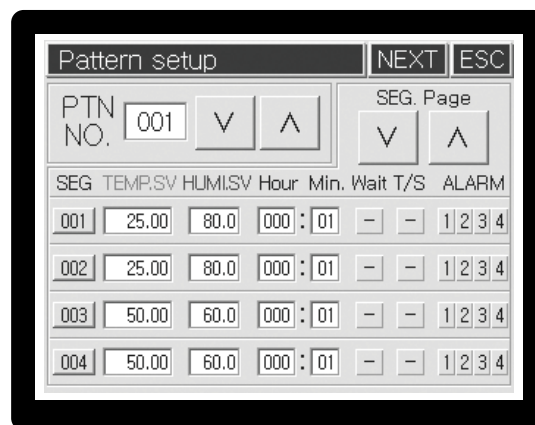

[Fig.19] Pattern Set Screen

Move to the running stopped screen 1 for program control after input for all, and input a start segment No. in the pattern and program start pattern. And then, program control will be running if you press the  button.

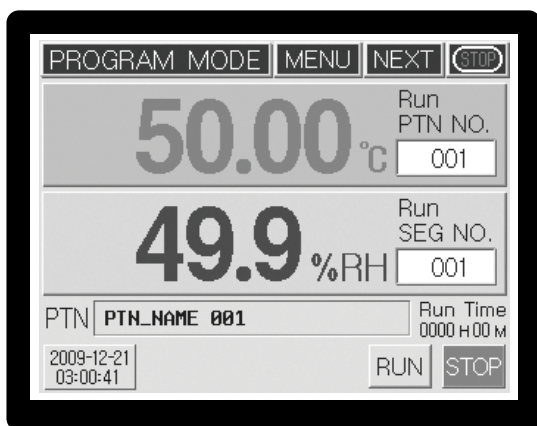

[Fig.20] Running stopped screen 1 for program control.

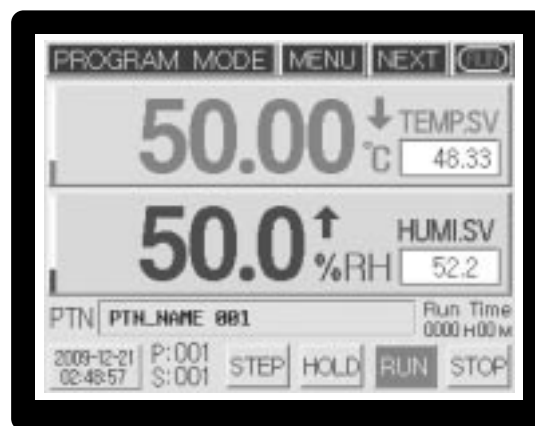

[Fig.21] Running screen 1 for program control

Once the program operation starts, **STEP** and **HOLD** buttons will appear newly like as running screen 1 for program control [Fig.21]. These buttons has function which is related to progress of segment.

Button	Function
STEP	It stops the currently processing operation of segment and runs the next segment operation. Pressing the STOP button on the wait status or hold status will cancel the hold function and runs the next segment of current segment immediately.
HOLD	Pressing the HOLD button while it is operating will keep the set value (set value which had been set right before performing HOLD function) disregarding the set time. Pressing the HOLD button on the hold status will cancel the hold function and runs the program. While it is in hold status, pressing the STEP button will cancel the hold status, skip current segment and run next segment immediately.

3.6 PID Auto Tuning

Auto Tuning (hereinafter referred to as A/T) is the automatic setting function in which the controller measures the characteristics of the control system automatically and calculates the optimal PID values accordingly. The A/T method measures and calculates a cycle by producing the ON/OFF control output for the two cycles and generating the limit cycle of controlled targets.

You can execute A/T all the time by entering a target setting value (SV) in the fixed control mode, pressing the **RUN** button, and pressing the subsequent either **T.A.T** or **H.A.T** button. After A/T is finished normally, if the unit is set to automatic PID ZONE reference mode, the resulted PID value will be saved into the appropriate PID ZONE. If this unit is set to manual PID ZONE reference mode, the results PID value will be saved into your designated PID ZONE.

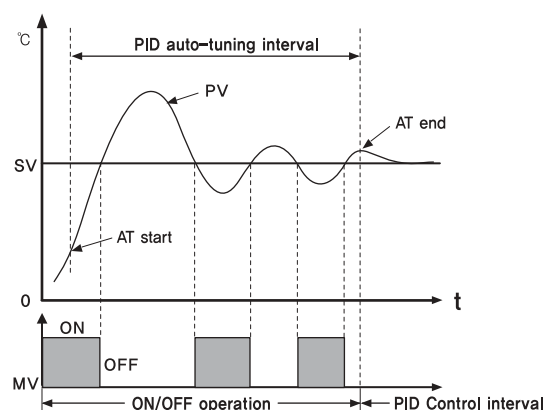

[Fig 22] P.I.D Auto Tuning



- If A/T still runs in 24 hours after A/T execution, A/T operation will come to an end automatically. If you close the A/T operation by force during A/T process, the operating value will not be saved and maintained as a previous setting value.

3.7 Graph display and setting

Graph's display screen is a screen to display the setting value and measured value of temperature and humidity.

In the graph setting screen, X axis's time and Y axis's maximum and minimum range can be set up by pushing each of **SETUP** buttons and set up saving operation status by selecting (**ALL ON** **RUN ON** **FIX ON** **Prog ON**), save period (seconds), and storing medium (**NONE** **USB M.STICK**)

In the Y axis's display range, temperature range or humidity range can be displayed by selecting Y **°C** **↔** **%** button.

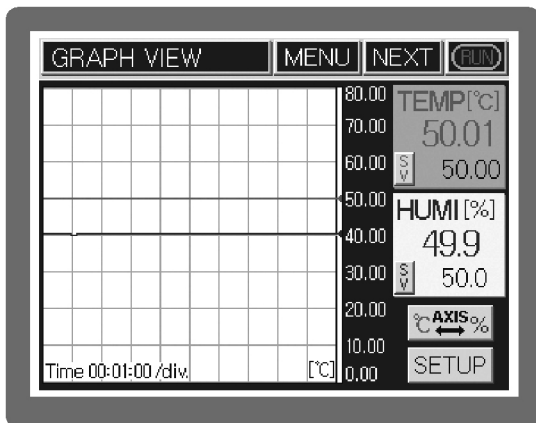

[Fig.23] Screen for fix control graph display

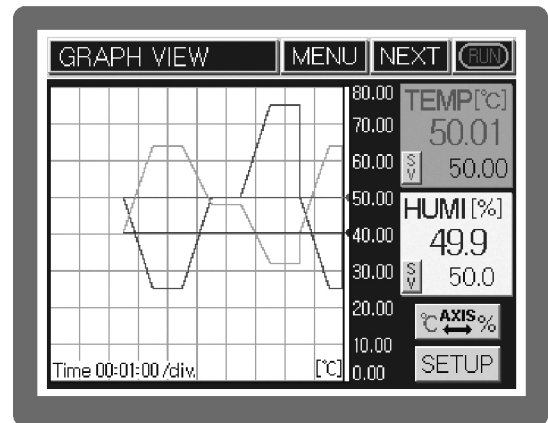

[Fig.24] Screen for program control graph display

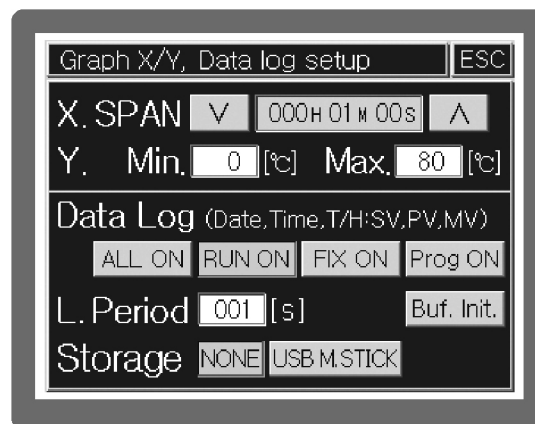

[Fig.25] Graph set screen

3.8 Error Indication

Running screen 2 for program control or fix control [Fig.26] is indicating an operating state for running.

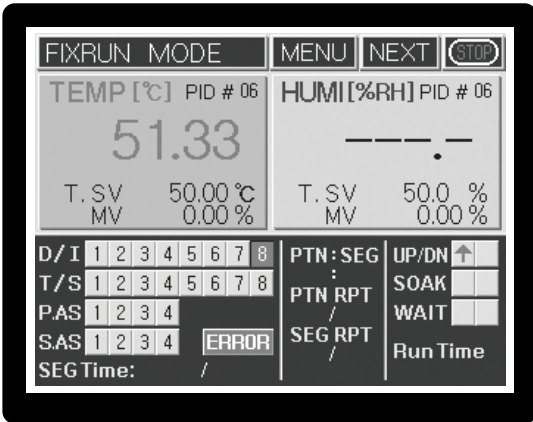

[Fig.26] Running screen 2 for fix control

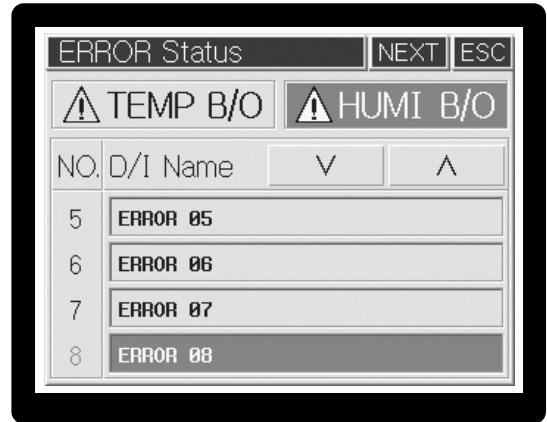

[Fig.27] Indication screen for occurrence of error

The indication of errors through sensor disconnection and external D/I is displayed with **ERROR** button on and off in the running screen 2 for program control [Fig. 26]. If you press the **ERROR** button, the error occurrence screen will appear. In this case, the error indicator for temperature & humidity disconnection will appear, while D/I(External contact input) no. 1 to 8 will be displayed on the bottom. You can check it by pressing the **V**, **^** arrow button.

Press the **NEXT** button to show the operating record indication screen which can check the state of RUNNING, STOP, Sensor Disconnection and External Contact Input (D/I).



[Fig.28] Operating Rec



When temperature or humidity sensor is disconnected, control operation will be stopped after passing sensor disconnection waiting time which was set in the SYSTEM SETTING..

4 Displays

Entire displays are mainly composed of three sections which are Working display, Function setting display(included In program installation) and System setting display.

4.1 Operating screen

After you finish to connect & turn on the power, Logo signal & System check display will be shown in a moment, and then Working display will be shown. In that time, according to selecting the initial setting program or Fixed driving method, it will be shown to Program control working display or Fixed control working display.

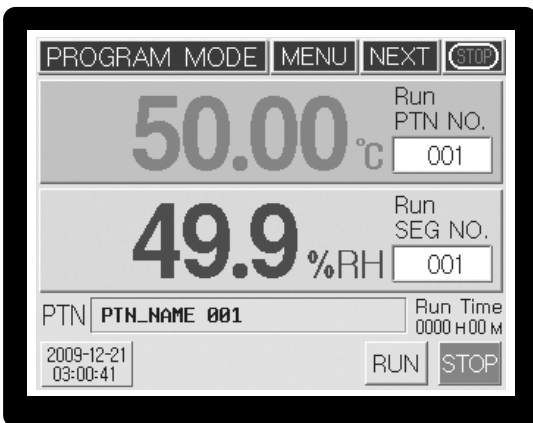

[Fig. 29]Program control the 1st working screen

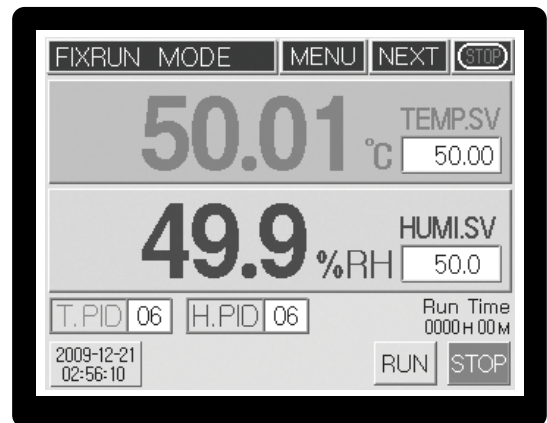

[Fig. 30]Fixed control the 1st working screen

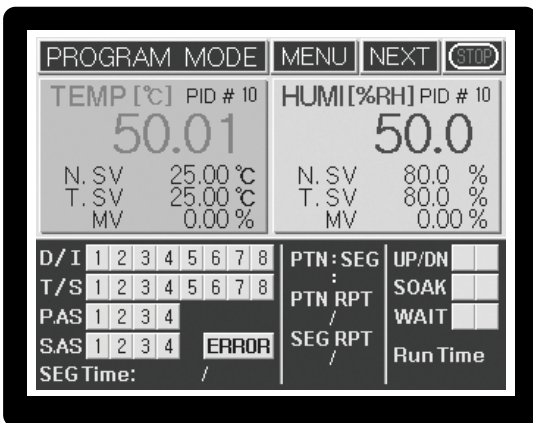

[Fig. 31]Program control the 2nd working screen

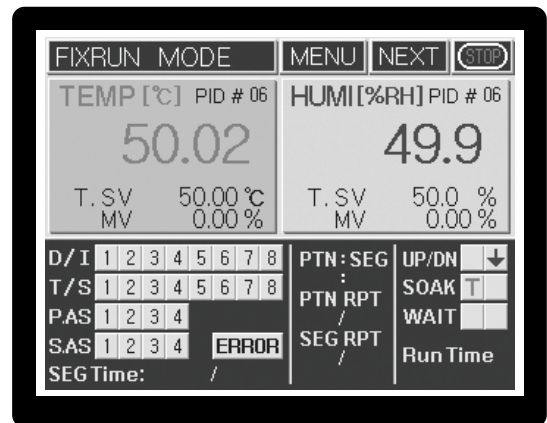

[Fig. 32]Fixed control the 2nd working screen

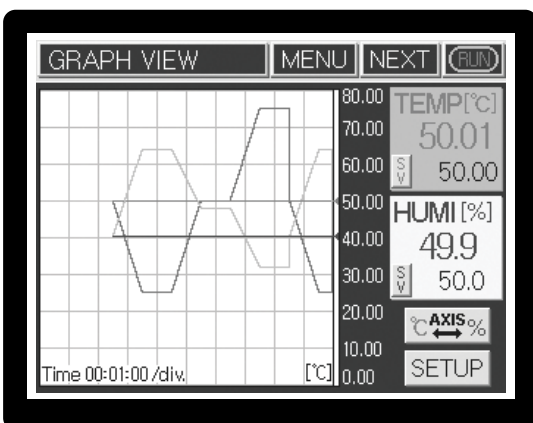

[Fig. 33]Program control Graph screen

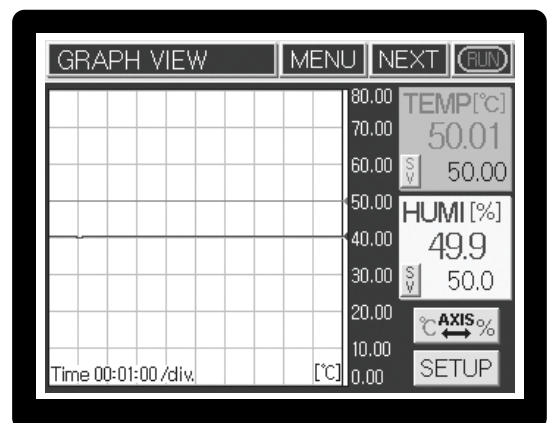

[Fig. 34]Fixed control Graph screen

4.2 Function setting display

After you push **MENU** button in working display condition, Function setting menu screen is shown. It is composed of 6 buttons. Push each button to set up under an item.

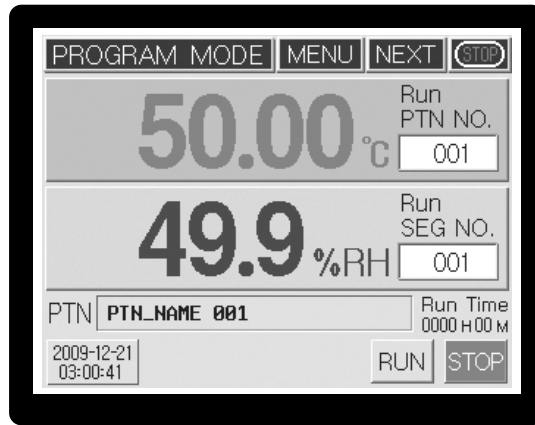

[Fig. 35] Program control the 1st stop screen

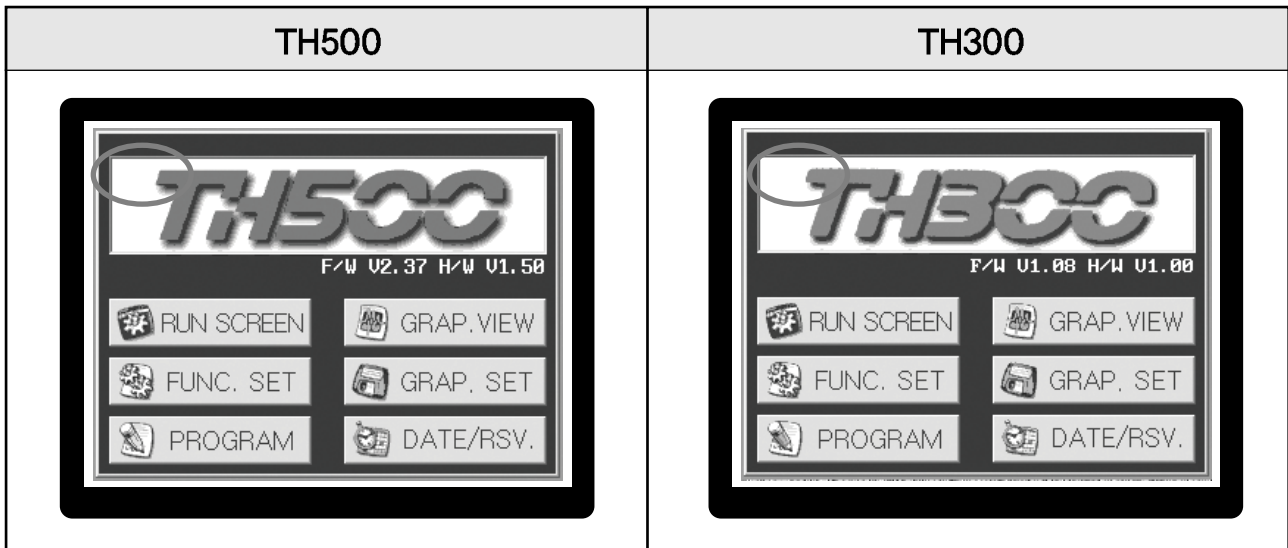

[Fig. 36] Function setting menu screen

4.3 System Setting screen

As pushing **MENU** button in Working display condition, Function setting menu screen is shown. Pushing the character of Function setting in that time, Password input display is shown. Pushing **ENT** after inputting (initial value: 0), the display of System setting function menu shows. It is composed of 8 buttons.

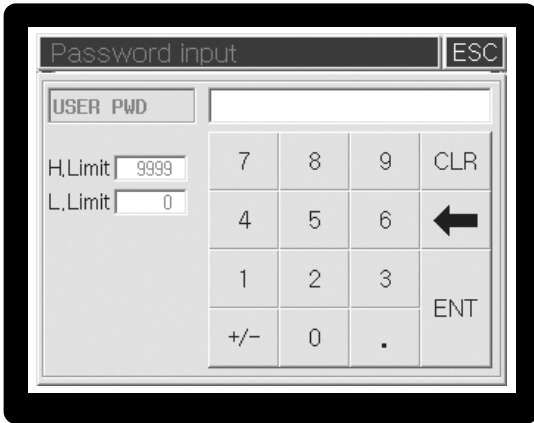

[Fig.37] Password input screen

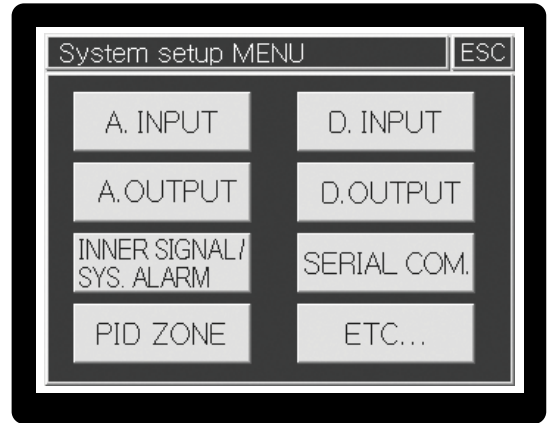

[Fig.38] System setting menu screen



There is no need for System setting made separately by driver. Because the Basic setting condition of this system's model is set up by the operator, you should be careful especially .

5 Function setting

After finishing installation & connection, turn on the power. Logo display & System check display are shown one after other. and then [Fig.39]fix control the 1st working stop screen is displayed.

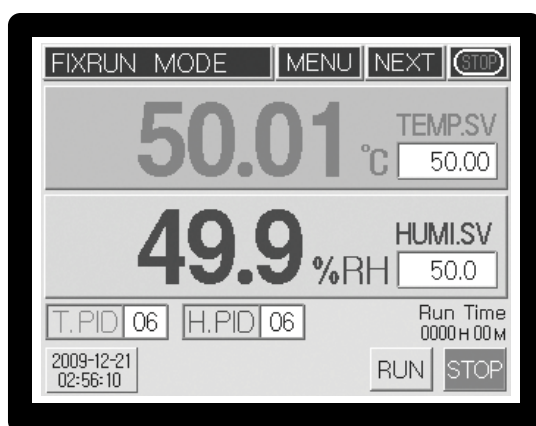

[Fig.39] Fix control the 1st working stop screen

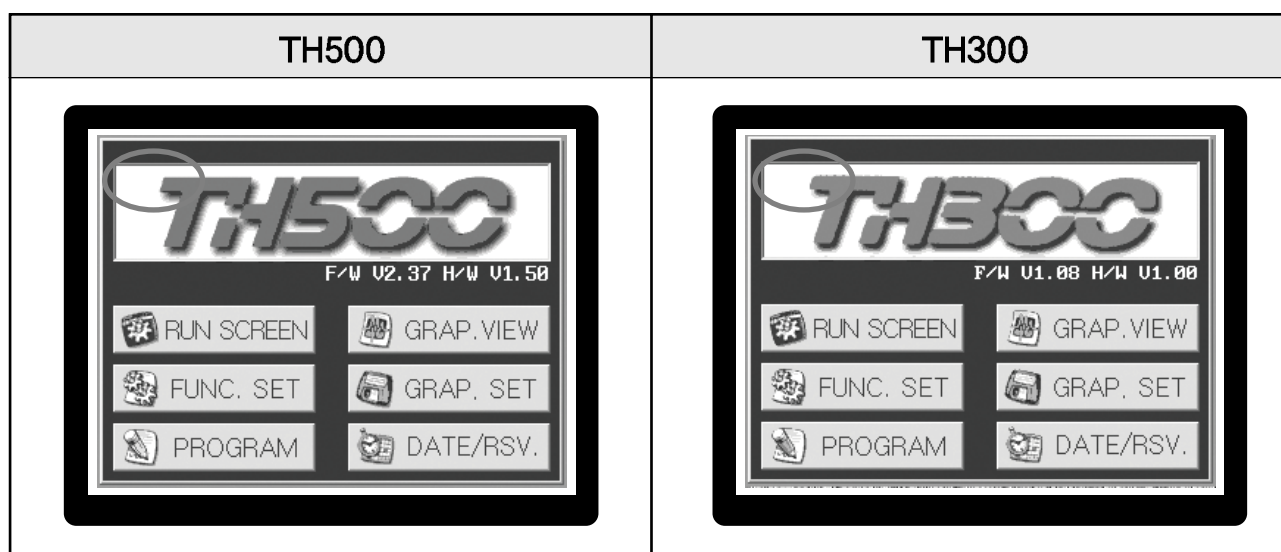

[Fig.40] Function setting menu screen

Function setting menu botton	Information	Function setting menu botton	Information
RUN SCREEN	Running Screen will be displayed.	GRAP. VIEW	Enter into Graph screen.
FUNC. SET	Running (Operation) Setting screen will be displayed.	GRAP. SET	Enter into axis X,Y and storage screen.
PROGRAM	Program Setting(Pattern, Time Signal setting etc.) screen will be displayed.	DATE/RSV.	Enter into Date/Time Reservation Setting screen.

5.1 Operation setting

5.1.1 Function setup 1

Pushing  button in [Fig.40]Function setting menu screen, you should select or set up each setting item of the function setup 1. Choose between Select Program control and Fixed control in selecting Working method.

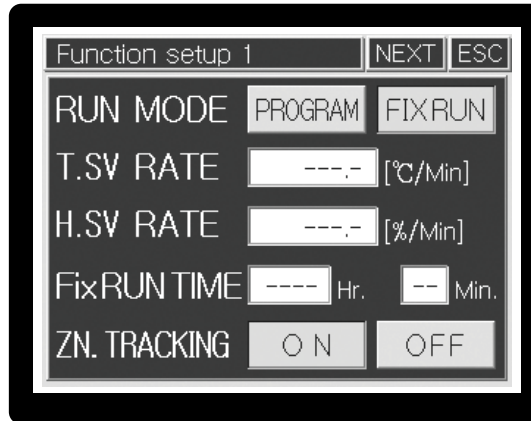

[Fig.41] Function setup 1 screen

RUN MODE	PROGRAM	Select in program control
	FIX RUN	Select in fixed control
T.SV RATE	Set it up as the gradient of temperature variations [°C/m] per hour (minute) from current temperature to setting temperature in fixed control.	
H.SV RATE	Set it up as the gradient of temperature variations [°C/m] per hour (minute) from current temperature to setting temperature in fixed control.	
Fix RUN TIME	After executing the fixed-mode control for the time entered, the operation will stop automatically.	
ZN. TRACKING	It prevents rapid output change when P.I.D ZONE is changed.	

5.1.2 Function setup 2

After finishing the setting of Function setup 1, press  button to set up the setting item of Function setup 2. In case outage occurs in working, it will be different with Operation condition in recovering outage by selecting BOOT RUN of Function setup 2 screen. (Only the power recovers within five seconds after outage, the same condition as before will be kept up.)

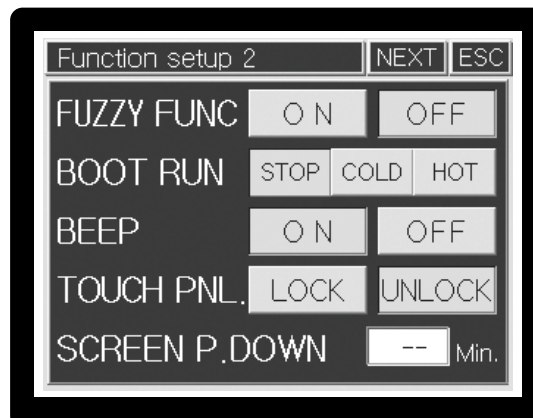

[Fig.42] Function setup 2 screen

FUZZY FUNC	It happens that measurement value is more than setting value in initial Over Shoot, select Fuzzy control. According to the load controlling Over shoot, the rising time can be delayed or Under Shoot can become larger in some cases.		
BOOT RUN	Program control		Fixed control
	STOP	STOP	STOP
	COLD	Start to operate again from the beginning	Start running in accordance with the set value before power failure.
HOT	Start to operate from the segment before		
BEEP	Turn on/off the buzzer sound to check various input and operation.		
TOUCH PNL.	It is used to limit the touch panel input during system control operating. Selecting Lock, it is impossible to input except MENU , NEXT and RUN / STOP buttons.		
SCREEN P.DOWN	As it is the function to turn off the power of Back-Light after the setting time in order to protect the LCD display, it can set up Setting time as a unit per a minute. Setting 0 when it is not used, it is turning on all the time.		

5.1.3 Function setup 3

After finishing Function Setup 2, please touch **NEXT** button to display Function Setup 3 screen. You can adjust LCD brightness by **-**, **+** button in the Function Setup 3.



[Fig.43] Function setup 3 screen

5.2 Program setting

[Fig.44] Press **PROGRAM** button in Function setting menu screen, Program setup menu will be shown. It is composed of 5 buttons. Push each button to set up under an item.

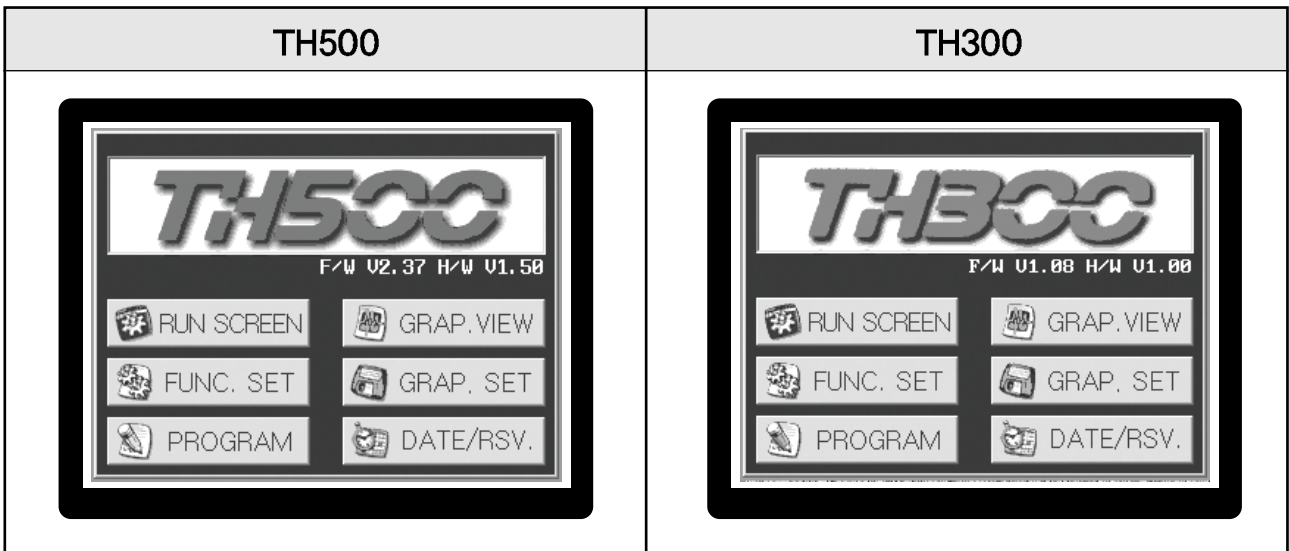

[Fig.44] Function setting menu screen

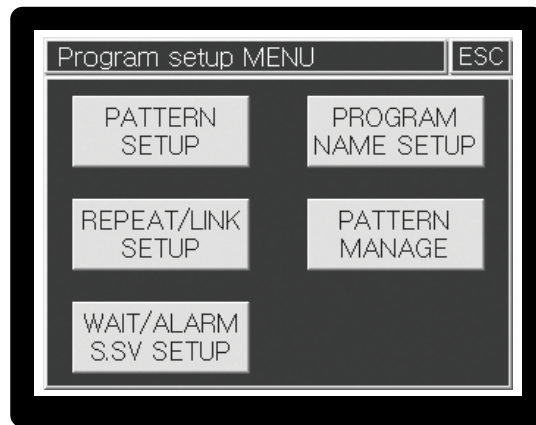

[Fig.45] Program setup menu screen

5.2.1 Pattern setting

[Fig.45] Pushing **PATTERN SETUP** button in Program setup menu screen, Program pattern setup screen is indicated. Set the agreeable segment of each pattern in this screen. Program control will process according to the content & sequence of segment designed.

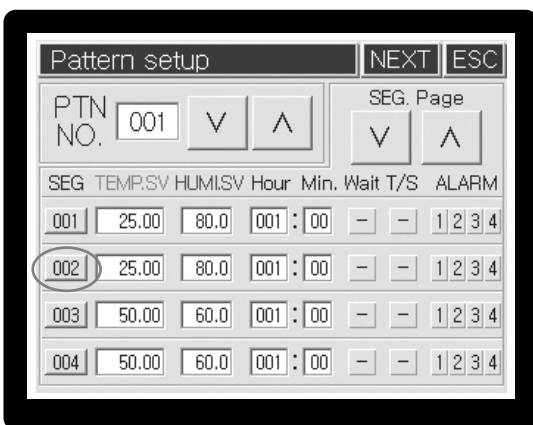

[Fig.46] Program pattern setup screen

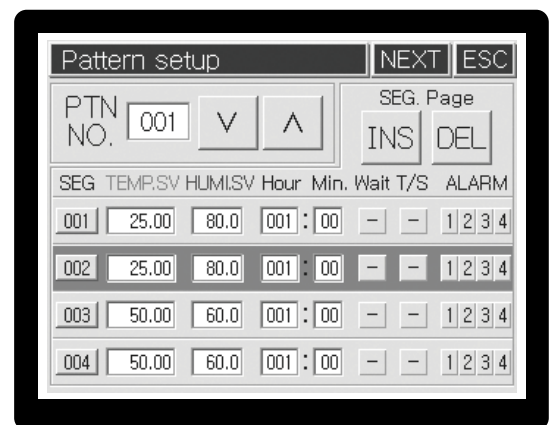

[Fig.47] Segment selection screen

● Setting each input item of [Fig.45] in reference of the diagram below.

Name	Function	Range
PTN NO.	Enter the pattern number [001] to set or select it by pressing the <input type="button" value="▲"/> / <input type="button" value="▼"/> button.	1 ~ 100 Pattern
SEG.Page	Pressing the <input type="button" value="▲"/> / <input type="button" value="▼"/> button, it moves each 4 segment.	
TEMP. SV	Pressing the setting window, set Temperature SV of segment.	-100~200 °C TH500
		-100~500 °C TH300
HUMI. SV	Pressing the setting window, set Humidity SV of segment.	0.0 ~ 100.0 %
Hour/Min	Setting operation time of segment.	0 hour ~ 255 hour 59 minute
Wait	Selecting waiting operation function set in waiting operation setting display.	ON/OFF
T.S.(Time Signal)	Selecting valid time signal in segment.	
ALARM	Selecting each action among 4 kinds of signal assigned in pattern signal setting display.[Fig.47]Pattern signal selection screen	1 ~ 4 each ON/OFF

● SEG. Insert/Delete

Pressing SEG number in the left side of [Fig.46], it is shown in red to segment moved & selected into SEG. Insert/Delete display.

SEG. Page button is changed into , button in that time. Pressing this button, Segment should be inserted or deleted and then the next Segment will be moved.

● Waiting/Pattern signal selection

Select Waiting, Pattern signal item of Program pattern setting display to execute contents set in Waiting Operation Setting display & Pattern Alarm Setting display (If you press button in Program setting display, Waiting Operation Setting display will be indicated.)

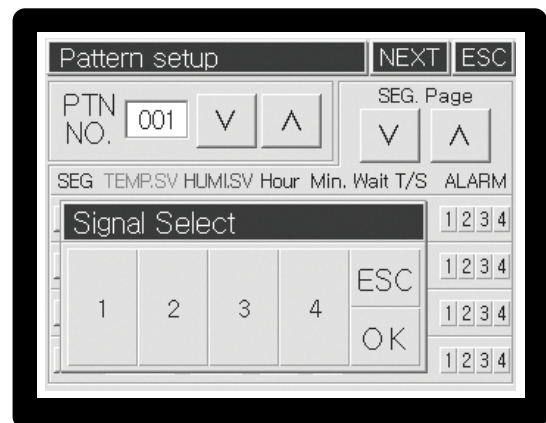

[Fig.48]Pattern Alarm selecting screen

5.2.2 Time Signal Setting

[Fig49] and [Fig50] screen will be displayed alternately when touching button in the Program Pattern Setting screen [Fig. 49] . Allocated Time Signal will be shown as blue color. When touching T/S button () on the Program Pattern Setting screen [Fig. 49] or Time Signal number on the Program Pattern Setting 2 screen [Fig. 50] , Time Signal Setting screen [Fig.51] will be displayed.

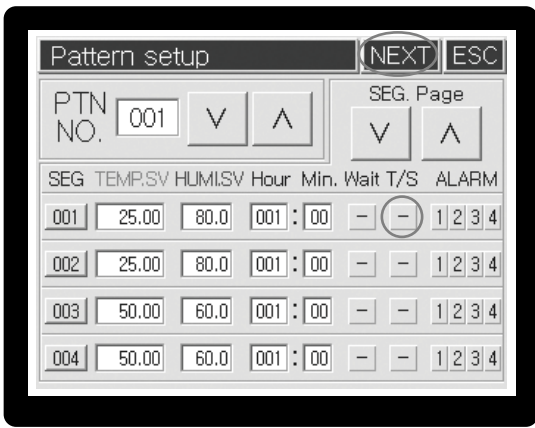

[Fig.49] Program Pattern Setting screen 1

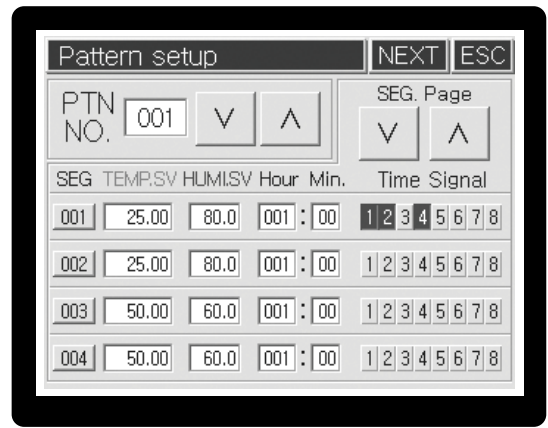

[Fig.50] Program Pattern Setting screen 2

Time Signal Setting Mode is divided into 2 types according to mode : SEG On/Off Mode and Time Setting Mode. Time Signal can be set to 8 points per each Segment.

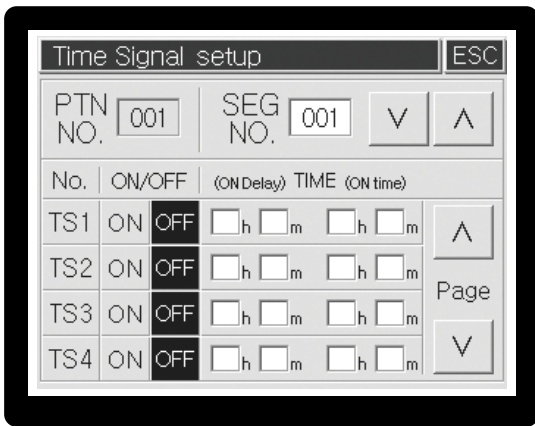

[Fig.51] Time Signal Setting

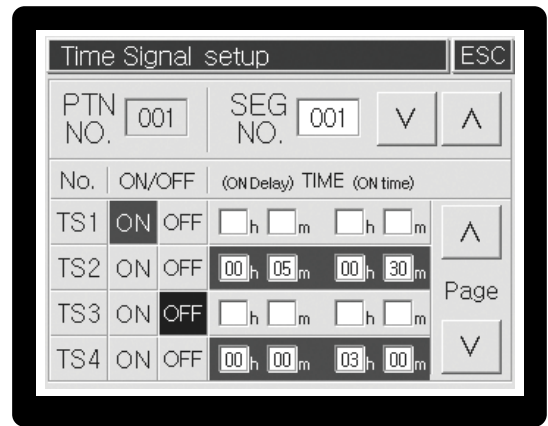

[Fig.52] Example of Time Signal Setting

Setting Mode		Function	Setting Range
SEG On/Off Mode		Set the Time Signal in ON, while segment is operating	Each segment
TIME (Time Setting Mode)	ON Delay	Set the Time Signal in ON, after setting time is delayed from the beginning of segment.	99 hour 59 min
	ON Time	Set the Time Signal in ON, during setting time from segment in ON.	99 hour 59 min

● Time signal segment ON/OFF setting method

[Fig.53] shows an example of using the T/S in ON/OFF mode. It performs turning on and off the T/S in the desired segment with the name of ON/OFF mode. The ON and OFF buttons are composed separately like [Fig.51]. Select by pressing or button, according to the desired Time Signal Operation.

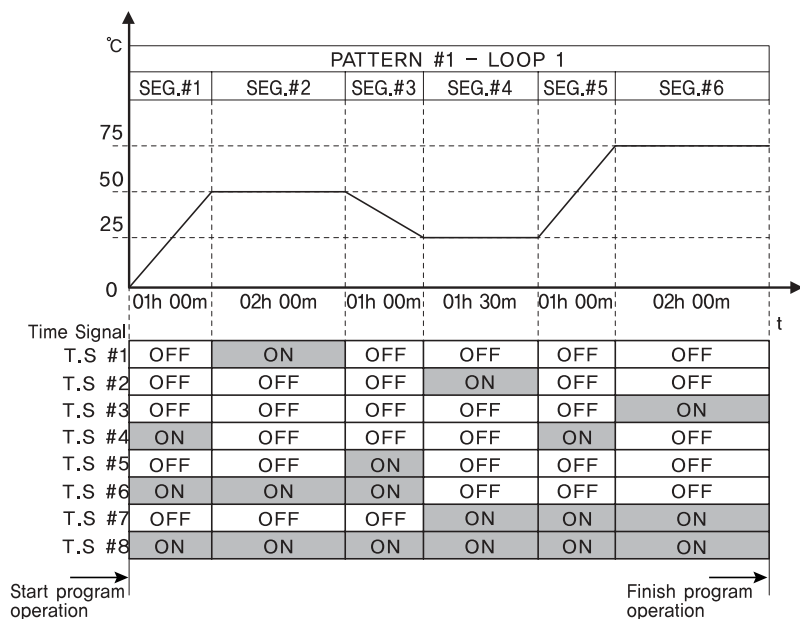

[Fig. 53] Example of Time Signal ON/OFF mode

Time Signal(T.S)	Description
T/S 1	SEG. 2 ON under 50°C soak status
T/S 2	SEG. 4 ON under 25°C soak status
T/S 3	SEG. 6 ON under 75°C soak status
T/S 4	SEG. 1 and SEG.5 ON under Up section
T/S 5	SEG. 3 ON under Down section
T/S 6	SEG. 1 to SEG. 3 ON
T/S 7	SEG. 4 to SEG. 6 ON
T/S 8	SEG. 1 to SEG. 6 ON under program control running

● Example of Setting the Time Signal in TIME Setting mode

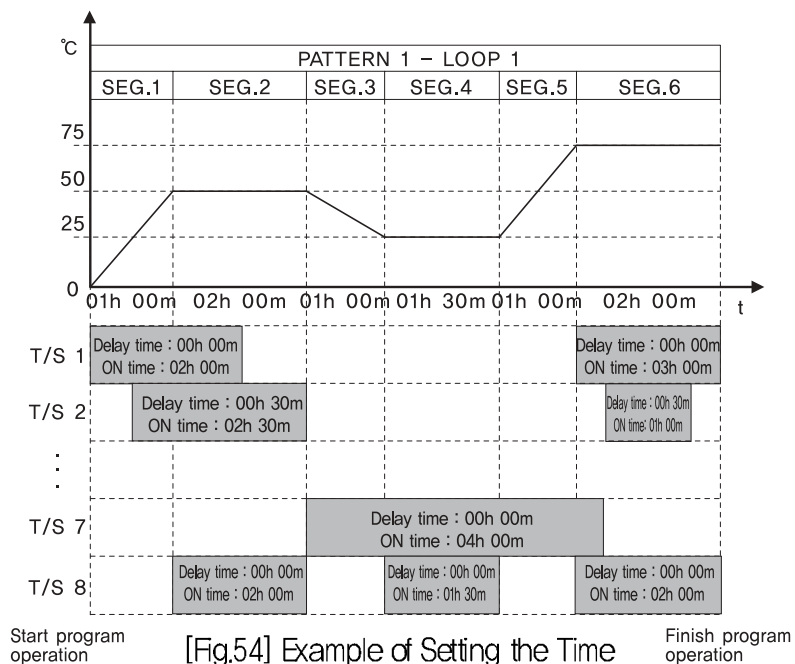

[Fig.54] Example of Setting the Time Signal in TIME Operation mode

Time Signal	Description
T/S 1	At the start point of segment 1, time signal becomes ON and after elapsing 2 hours, it will become OFF. (ON Delay : 00 h 00 m), (ON Time : 02 h 00 m) At the start point of segment 6, time signal becomes ON and after elapsing 2 hours, it will become OFF. (Since segment 6 is 2 hours, it only yield the output for 2 hours even if On Time is set as 3 hours) (ON Delay : 00 h 00 m), (ON Time : 03 h 00 m)
T/S 2	At the start point of segment 1, time signal becomes ON after delaying 30 minutes and becomes OFF after elapsing 2hour30minutes. (ON Delay : 00 h 30 m), (ON Time : 02 h 30 m) At the start point of segment 6, time signal becomes ON after delaying 30 minutes and becomes OFF after elapsing 1hour (ON Delay : 00 h 30 m), (ON Time : 01 h 00 m)
T/S 7	At the start point of segment 3, time signal becomes ON and after elapsing 4 hours, it will become OFF. (ON Delay : 00 h 00 m), (ON Time : 04 h 00 m)
T/S 8	Time signal becomes ON in each of segment 2, 4 and 6 and after elapsing ON time, it will become OFF.



Time Signal will be OFF once the program ends regardless of setting modes.

5.2.3 Pattern repeat/Link setting

Pressing PROGRAM button in [Fig.44]

Function Setting menu screen, and pressing



button in [Fig.45], Pattern REPEAT/LINK

setup [Fig.55] is shown. If you set Current Pattern repeat count to Pattern repeat on the right side of the top and Current Pattern number to connect Pattern, Current pattern will be run in unlimited repeat according to Segment Operation. Program operation executes inputted segment in sequence basically, but it comes occasionally that the case of set segment contents in pattern should be repeated & executed. Using Section repeat in that time, reduce Program input as much as possible. You can move among Section repeat setting pages by using the / arrow buttons on the right side in the order ranging from 1 to 20 in total.

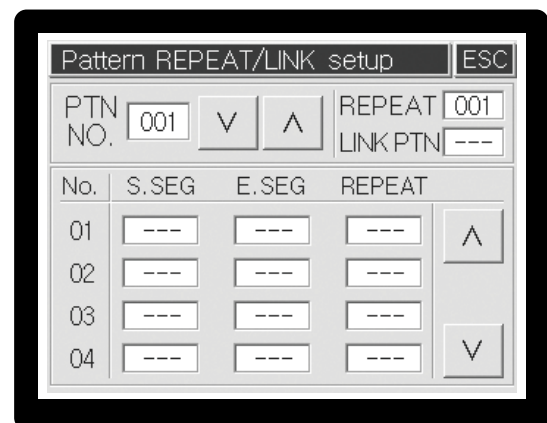

[Fig.55] Pattern repeat/Connect setting screen

Name	Function	Range
PTN NO.	Enter the pattern number to set or select it by pressing the Up/Down button.	1~100 Pattern
REPEAT	Set the repeating number of pattern.	1~999 Time
LINK PTN.	Set the pattern number for next operation (Operation of pattern number after completing the operation of current pattern). Setting [0] will stop the operation without performing next operation.	0~100 Pattern
No.	This is partial repeating series number which affords total 20 partial repetitions per pattern and it runs from number 1 to 20 in consecutive order.	1~20 Number
S.SEG	Set the partial repeating start segment number. Setting [0] will run the next partial repetition number.	0~100 SEG
E.SEG	Set the partial repeating end segment number. Setting [0] will run the next partial repetition number.	0~100 SEG
Section repeat	Set the number of current partial repetition. Setting [0] will run the next partial repetition number.	0~255 Time

※ ● The Segment operation sequence by Section repeat setting

If segment in pattern is set from ① to ⑧, it operates like below according to Section repeat Setting.



Section repeat serial number	Section repeat setting			Segment operation sequence	
	Start Seg	End Seg	Repeat		
ex1	1~20	0	0	①Seg → ②Seg → ③Seg → ④Seg → ⑤Seg → ⑥Seg → ⑦Seg → ⑧Seg	
ex2	1	③	⑥	2	① → ② → ③ → ④ → ⑤ → ⑥ ③ → ④ → ⑤ → ⑥ → ⑦ → ⑧
ex3	1	③	⑥	2	① → ② → ③ → ④ → ⑤ → ⑥ ③ → ④ → ⑤ → ⑥
	2	④	⑤	2	④ → ⑤ ④ → ⑤ → ⑥ → ⑦ → ⑧
ex4	1	②	③	2	① → ② → ③ ② → ③
	2	①	④	2	① → ② → ③ → ④ ① → ② → ③ → ④ → ⑤ → ⑥ → ⑦ → ⑧
ex5	1	②	③	2	① → ② → ③ ② → ③ → ⑥ → ⑦
	2	⑥	⑦	2	⑥ → ⑦ → ⑧
ex6	1	⑤	⑦	2	① → ② → ③ → ④ → ⑤ → ⑥ → ⑦ ⑤ → ⑥ → ⑦
	2	②	③	2	② → ③ ② → ③ → ④ → ⑤ → ⑥ → ⑦ → ⑧

※ Partial repeating per 1 pattern can be set up to 20 (partial repeating serial number)

Section repeat serial number	Section repeat setting			Segment operation sequence	
	Start Seg	End Seg	Repeat		
ex7	1	⑥	⑦	2	① → ② → ③ → ④ → ⑤ → ⑥ → ⑦ ⑥ → ⑦
	2	②	③	2	② → ③ ② → ③ → ④ → ⑤ → ⑥ → ⑦ → ⑧
ex8	1	①	⑧	1	① → ② → ③ → ④ → ⑤ → ⑥ → ⑦ → ⑧
	2	②	⑦	1	② → ③ → ④ → ⑤ → ⑥ → ⑦
	3	③	⑥	1	③ → ④ → ⑤ → ⑥
	4	④	⑤	1	④ → ⑤
	5	⑤	⑤	2	⑤ ⑤
	6	①	⑧	2	① → ② → ③ → ④ → ⑤ → ⑥ → ⑦ → ⑧ ① → ② → ③ → ④ → ⑤ → ⑥ → ⑦ → ⑧
	7	⑦	⑦	2	⑦ ⑦ → ⑧

※ Partial repeating per 1 pattern can be set up to 20 (partial repeating serial number)

5.2.4 Waiting/Alarm start mode setting

Press  PROGRAM  WAIT/ALARM SSV SETUP button in function setting menu screen to move Pattern Wait setup screen. Waiting operation can be set by each segment of proper pattern. In case that Waiting operation of Measurement value(MV) comes or fails to come within Waiting range of Set value(SV), wait process of segment during setting Waiting operation time and then go to next segment.
(Only if Waiting operation is set to '0', Waiting operation will not work).

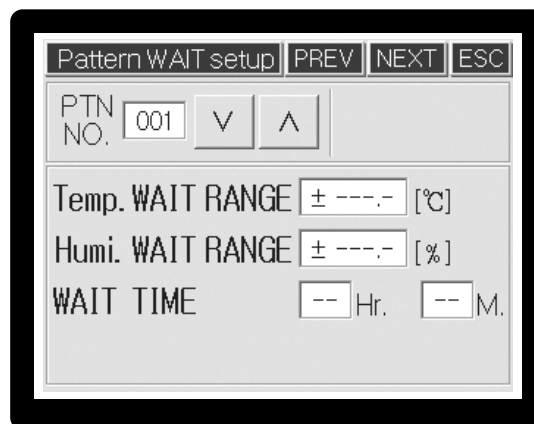

[Fig.56] Pattern WAIT setup screen

Name	Function	Range
PTN NO.	Enter a pattern number to be set or select it by pressing the <input type="button" value="▲"/> / <input type="button" value="▼"/> button.	1~100 Pattern
Temp. WAIT RANGE	Set the deviation range about the temperature set value which will be applied to the standby operation.	(0 ~ ±300) °C(TH500) (0 ~ ±600) °C(TH300)
Humi. WAIT RANGE	Set the deviation range about the humidity set value which will be applied to the standby operation.	(0 ~ ±100) %
WAIT TIME	Until it satisfies the deviation range about the set value which will be applied to the standby operation, it sets the time that delays the process of segment. When both of temperature and humidity standby range are being set, both of them must fall within standby operation range in order to cancel the standby operation.	0 ~ 99 hour 59 minute

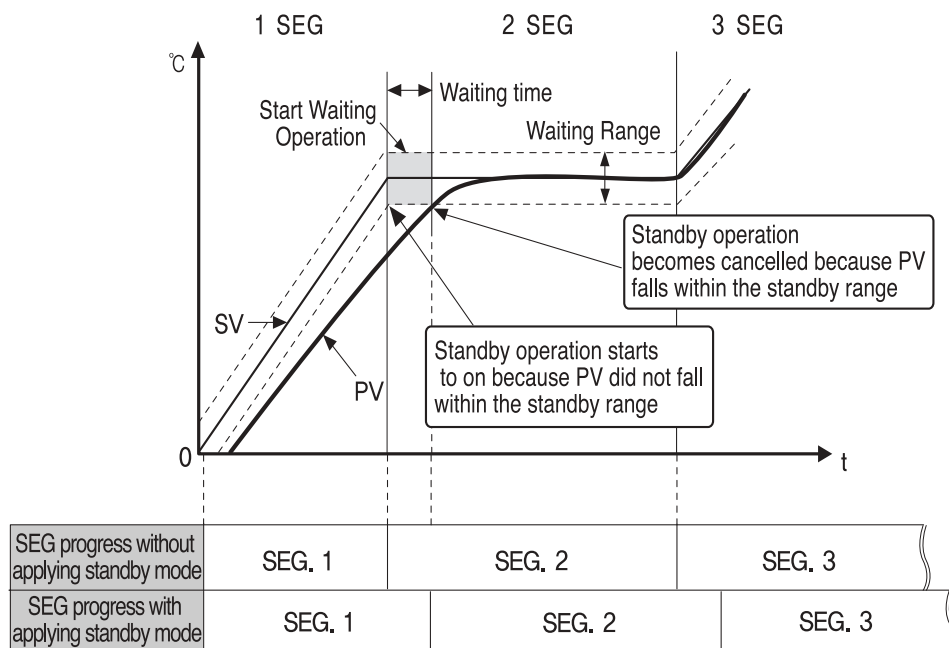

[Fig 57] Common waiting operation

[FIG 57] generally display the standby operation. If process value (PV) does not fall within the standby range at the changing point from SEG1 to SEG2, it will wait until process value (PV) falls within the standby range (wait for the set standby time). Here, if standby time elapses, it will process to the SEG 2 even if the process value (PV) did not fall within the standby range [FIG 58].

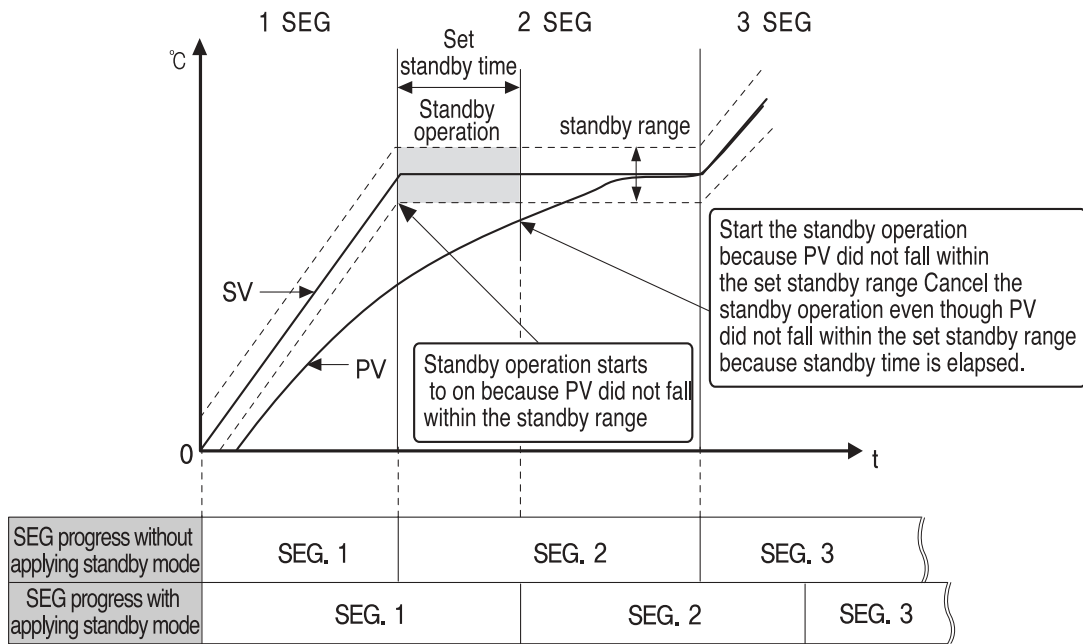

[FIG.58] Standby action cancellation due to the elapse of standby time

5.2.5 Pattern Alarm Setting

Within the function setting menu [FIG 44] screen, press **PROGRAM** **WAIT/ALARM S.SV SETUP** buttons to enter into the standby operation setting [FIG 56] screen. After that, press the **NEXT** button to enter into the pattern alarm setting [FIG 59] screen.



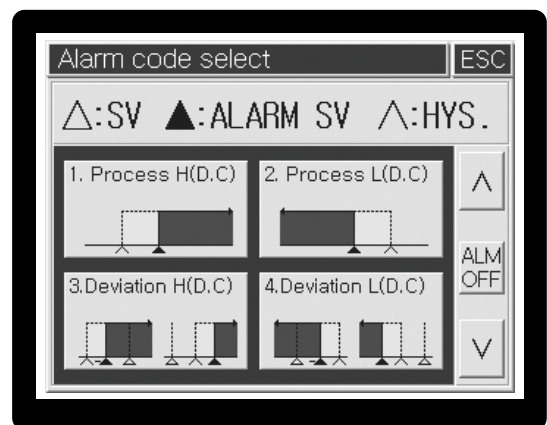

[FIG.59] Pattern alarm setup screen



[FIG.60] Alarm code selection

Pattern alarm setting [FIG 59] screen is the setting screen that sets the alarm 1~4 which will be used within the pattern. The alarm value which was set within this screen can select the pattern alarm 1~4 of each segment. Alarm type is same as the [Table 2] alarm type and code. Also, in order to input the target alarm code after selecting the temperature and humidity, press the code display unit then alarm code setting [FIG 60] screen will be displayed.

Display the target alarm code by pressing the ,  button. After that, pressing the indicated screen will input the alarm code to the pattern alarm setting [FIG 59] screen code automatically. If users want to cancel the set alarm code, press the  button (located on the right middle side of alarm code setting [FIG 60] screen) then set alarm code will be cancelled.

● [Table2] Alarm Type & Code

Code	Alarm Type	Code	Alarm Type	Operation View
1	Upper limit absolute (Tangent)	11	Upper limit absolute (Tangent, Hdd)	
2	Lower limit absolute (Tangent)	12	Lower limit absolute (Tangent, Hdd)	
3	Upper limit deviation (Tangent)	13	Upper limit deviation (Tangent, Hdd)	
4	Lower limit deviation (Tangent)	14	Lower limit deviation (Tangent, Hdd)	
5	Upper limit deviation (Reciprocal)	15	Upper limit deviation (Reciprocal, Hold)	
6	Lower limit deviation (Reciprocal)	16	Lower limit deviation (Reciprocal, Hold)	
7	Upper & lower limit deviation	17	Upper & lower limit deviation (Hold)	
8	Within the range of upper & lower limit deviations	18	Within the range of upper & lower limit deviations (Hold)	
9	Upper limit absolute (Reciprocal)	19	Upper limit absolute (Reciprocal, Hold)	
10	Lower limit absolute (Reciprocal)	20	Lower limit absolute (Reciprocal, Hold)	

△ : SV ▲ : Alarm SV

5.2.6 Pattern start mode setting

The initial setting value is necessary to ascent or descent by the setting value of 1st segment when you start to work with Program control. Select this the initial setting value between Start setting value(S.SV) and Current measurement value(S.PV). Pressing **WAIT/ALARM S.SV SETUP**, **NEXT** buttons in Program setting menu display, Pattern alarm setting display will be shown. Pressing **NEXT** button again In this display, it will be shown to [Fig.61] S.PV Working start setting display.

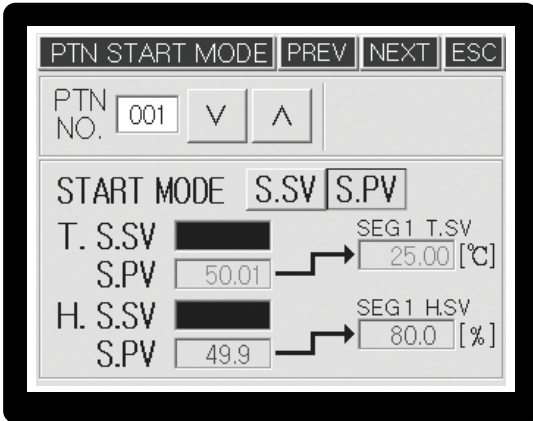

[Fig.61] S.PV Operaiton start setting display

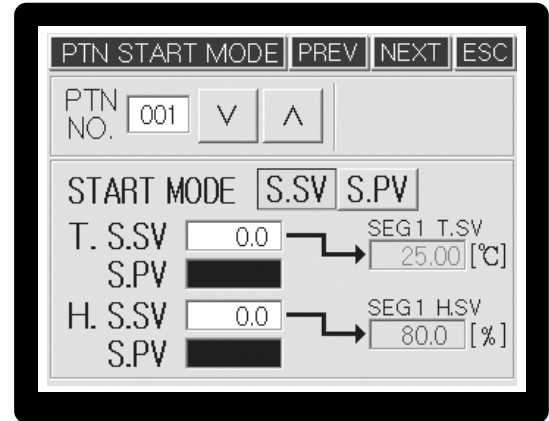

[Fig.62] S.SV Operation start setting display

Name	Function	Range	
PTN NO.	Enter the pattern number to set or select it by pressing the ↓ / ↑ button.	1~100 Pattern	
START MODE	S.SV	Start the operation based on the SV set in the temperature & humidity S.SV below.	-
	S.PV	Start the operation based on the current	-
T. S.SV	Set to the start SV upon temperature program running.	(-100~200) °C (TH500) (-100~500) °C (TH300)	
H. S.SV	Set to the start SV upon humidity program running.	(0~100) %	

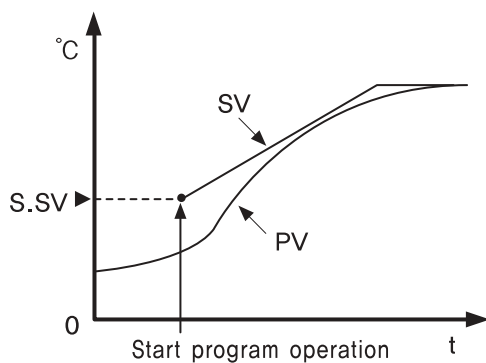

[FIG.63] S.SV Operation start mode

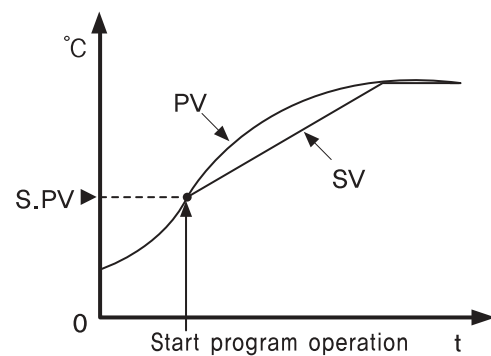

[FIG.64] S.PV Operation start mode

5.2.7 Program pattern name setting

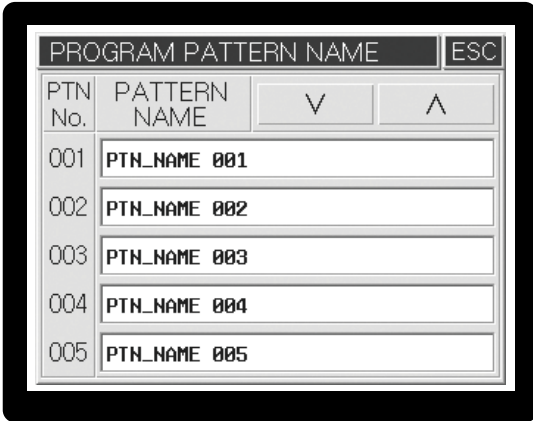

[Fig.65] Program pattern name screen

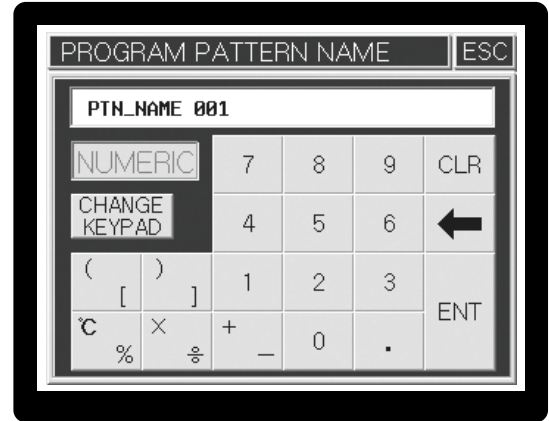

[Fig.66] Number input screen

When pressing pattern name in the Program Pattern Name setting screen [Fig.65], Number Input Screen [Fig.66] will be shown. When pressing PROGRAM button in the function setting menu, Program setup menu screen will be shown. Pressing PROGRAM NAME SETUP leads to Program pattern name screen. When pressing the Program pattern name you want by means of right-upper side button, Number input screen [Fig.66] will be shown. Enter the desired pattern number by CHANGE KEYPAD button.

5.2.8 Pattern/Segment management

[Fig.67] is the display for managing patterns through pattern copy, segment copy and segment initializing. In the left side you should enter the source pattern or segment number used for pattern management. In the right side you should enter the target pattern number or segment number to be copied. After entering a desired value, you can

copy it by pressing PTN.COPY, SEG.COPY button in arrow. Pattern Clear button on the left center is used for initializing all the internal segments of the pattern entered into the input box above. Pressing PTN.COPY, it will be copied to contents related with every segment in internal pattern. Pressing [Fig.67] Segment management SEG.COPY button, it will copy contents of the original start/End segment copy from a copy start segment. It is possible

to copy segment into your desired position by inserting different segment numbers of the right copy when copying segment. (Example : the original 1~6 to the copy 7~12)

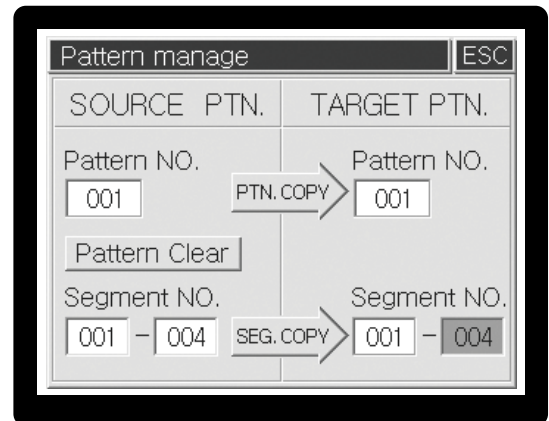

[Fig.67] Pattern/Segment management



- Keep in mind that it is impossible to recover the original contents of the target after copying the pattern/segment. Once you press the **Pattern Clear** button, the original contents of the source cannot be recovered again. After copying pattern by using **PTN.COPY** button, you should make sure that the related parameter is proper setting. (Repeat, Connect, Waiting, Alarm, Start mode, ect)

5.3 Date/Time Reservation Setting

Date/Time Reserve RUN setup [Fig.68] will be shown when pressing **DATE/RSV.** After entering (Year,Month,Date,Hour,Minute) into the indication screen of [Current Time] and pressing **SET** value, Date and Time will be set up. RUN(Operation) method by means of Reservation Time Setting is same as Current Time Setting method. After Reservation Time Setting and move to the Running screen of fixed control[Fig.69], **RESERVED** screen will be on and off and shown. If reservation time comes, it turns into RUN status. In order to cancel **RESERVED** , please press flickering "Reservation Waiting" and select **YES**.

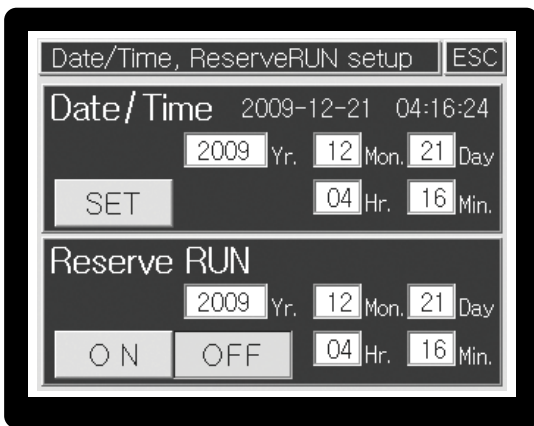

[Fig.68] Reservation time setting screen

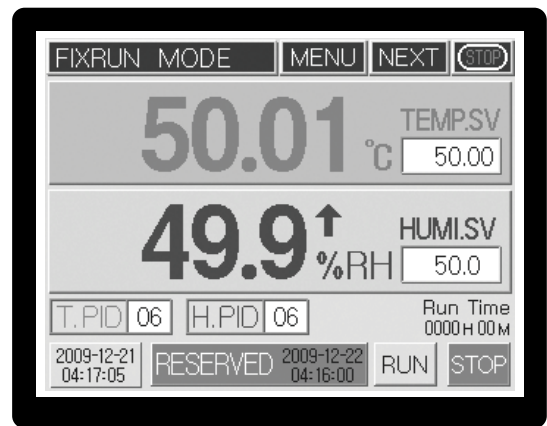



[Fig.69] Fixed control the 1st working stop screen



- If you begin to work by pressing **RUN** button during reservation waiting, reservation waiting will be canceled automatically and the operation will start. Likewise, if you start the 「RUN/STOP」 operation through Contact input(D.I), reservation waiting will be canceled automatically

5.4 Graph/Save Setting

When touching  in the Function setting menu screen[Fig.44] or touching  in the Graph Display Screen[Fig.71], Graph Setting screen[Fig.70] will be shown up. In the Graph setting screen[Fig.70], the time of X axis means the time per division and as table 3, it can be designated to min 20 seconds ~ max 216 hours according to its internal setting. If you want to use Y axis as temperature, within $-100\text{ }^{\circ}\text{C}$ min ~ $200\text{ }^{\circ}\text{C}$ max(TH500) and $-100\text{ }^{\circ}\text{C}$ min ~ $500\text{ }^{\circ}\text{C}$ max (TH300), you can select at least $8\text{ }^{\circ}\text{C}$. In case of displaying as humidity, its value is fixed as 0 – 100 %.

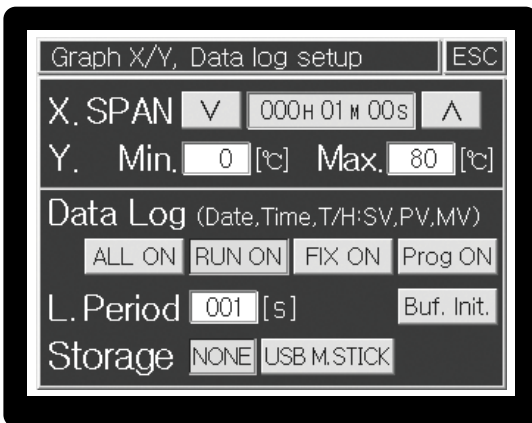

[Fig.70] Graph Setting screen

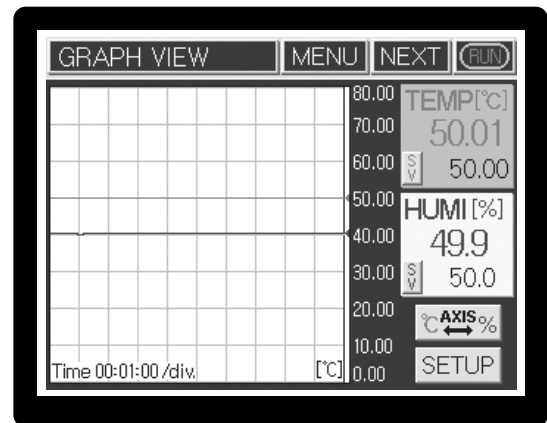







[Fig.71] Graph view screen

● [Table 3] Time per X axis DIV

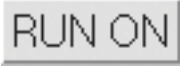
Division	Setting Time	Entire Screen Time
1	00M 20S	00H 03M 20S
2	01M 00S	00H 10M 00S
3	02M 00S	00H 20M 00S
4	03M 00S	00H 30M 00S
5	04M 00S	00H 40M 00S
6	05M 00S	00H 50M 00S
7	06M 00S	01H 00M 00S
8	07M 00S	01H 10M 00S
9	08M 00S	01H 20M 00S
10	09M 00S	01H 30M 00S
11	10M 00S	01H 40M 00S
12	20M 00S	03H 20M 00S
13	00H 30M	05H 00M
14	00H 40M	06H 40M

Division	Setting Time	Entire Screen Time
15	00H 50M	08H 20M
16	01H 00M	10H 00M
17	02H 00M	20H 00M
18	03H 00M	30H 00M
19	04H 00M	40H 00M
20	05H 00M	50H 00M
21	06H 00M	60H 00M
22	09H 00M	90H 00M
23	12H 00M	120H 00M
24	24H 00M	240H 00M
25	48H 00M	480H 00M
26	72H 00M	720H 00M
27	144H 00M	1440H 00M
28	216H 00M	2160H 00M

● [table 4] Selection of storage condition

Button	Name	Function
	ALWAYS ON	Save always.
	RUN ON	Save during controlling only.(Fix/Program)
	FIX-RUN ON	Save during fixed-mode controlling only.
	Program-RUN ON	save during program mode controlling only.
	Internal Buffer initialize	Delete/Initialize Saved Contents in internal memory
	USB cancellation	Do not use USB MEMORY STICK.
	USB selection	Record on USB MEMORY STICK.

As far as the saving operations are concerned, the total 86,400 pieces of information on temperature & humidity (Y/M/D, temperature & humidity SV/PV/MV) under current controlling will be recorded to the internal memory. The saving cycle can be designated as 1 to 360 seconds. Therefore, if the saving cycle is 1 second, it can save for one day. On the other hand, if the saving cycle is 30 seconds, it can save for 30 days.. Also recorded data will be stored in accordance with table 4 : Selection of storage condition. When selecting , it will be recorded on USB MEMORY STICK. But it requires to connect USB MEMORY STICK with our product name "EM310(Sold separately).

● Data transmission by USB connector

TH500 present USB connection function to send saved data to PC. According to Save Sequence & Save Operation Mode set in [Fig.70] Graph Setting display, Data stored in internal memory become mass difficult to transfer with low-speedy connection (max 115,200 BPS) interface like RS232, RS422/485. If you send by using USB connection in that time, it is possible to send to PC within a few second.

[Fig.72] is the display of USB Up-loader software presented by HANYOUNG NUX CO., LTD. When USB connector is connected, Device connecting status is indicated,

“Connected” in blue and  button is activated. Pressing Send button, you

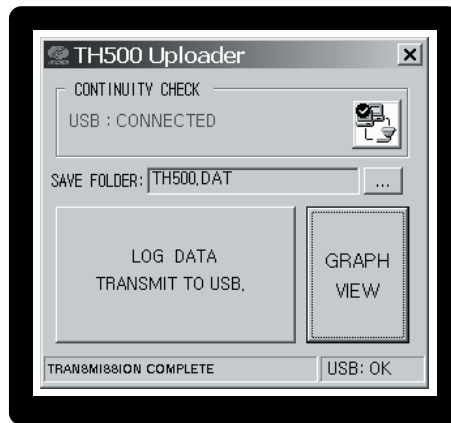

[Fig.72] USB Uploader Utility

can receive every Measure/control value recorded in TH500 through USB. Transferred data is stored in the folder of "C:\TH500_DATA". Because all saved Data file is in text mode, you can see the content of saved data file with any editor, word-processor or Excel. It is possible to see a graph by using Graph Viewer program presented.



- If you turn off, all contents will be deleted because the value of saved measurement & control is saved in Volatile Memory(SDRAM).
- When you connect USB, you must use USB A-B connector cable.
- The USB Plug & Play function of some PCs may have errors upon PC booting. Therefore, it is necessary to connect USB connector after PC booting. After PC booting, you are free to connect USB connector.

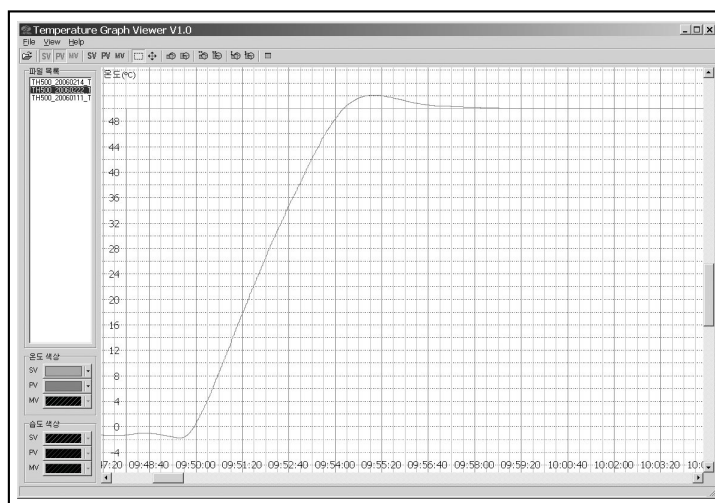

[FIG.73] Graph viewer program

6 System Setting



- Caution : System setting is a pre-installed basic setting condition so you need special attention when you change them.
- There is no need for operator to set System setting separately. Because the basic setting condition of this system is already set up by system installation company, operator should be careful when changing System setting.

If you push **MENU** on operation screen, function setting menu screen will be displayed. And if you push function-setting , Password screen will be displayed (initial value: 0). and then you can enter system setup menu screen after pushing **ENT** on screen.



[Fig. 74] Function setting menu screen

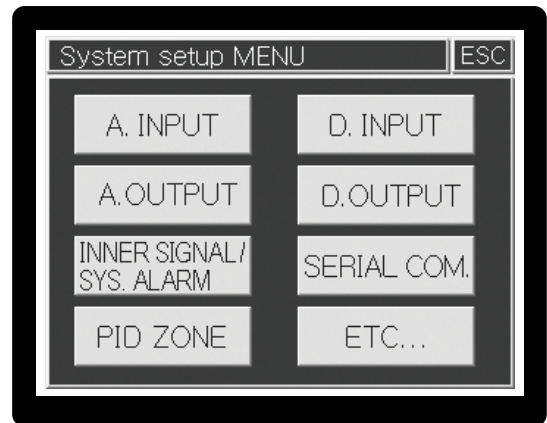

[Fig. 75] System setup menu screen

6.1 Sensor type setting

Our temperature and humidity controller (Model # TH500/TH300) support various outputs and inputs so you need to set output and input information before using this controller.

On the operation screen, push screen as following,

When touching **MENU** button in the Operation screen, Function Setup screen will be shown up. This time, if you touch left-top corner, Password confirmation screen will be displayed (Initial value : 0). After touching password and then touching **ENT** , System Setup menu screen will be shown up. When touching Sensor Input Setup button, Temperature sensor setting screen[Fig.76] will be displayed and it is consisted of total 4 screens (Sensor Input Setting 1~4)

6.1.1 Sensor Input Setting 1 & 2

It is possible to set sensor type(R.T.D/V d.c), Input range, Scale(Measurable range setting), Sensor Bias, Filtering time on the Temperature sensor setting screen[Fig.76]. The contents of Humidity sensor setting screen[Fig.77] is the same as temperature sensor setting. But, if you select sensor type as **OFF** , Temperature only display [Fig 78] will be set up.

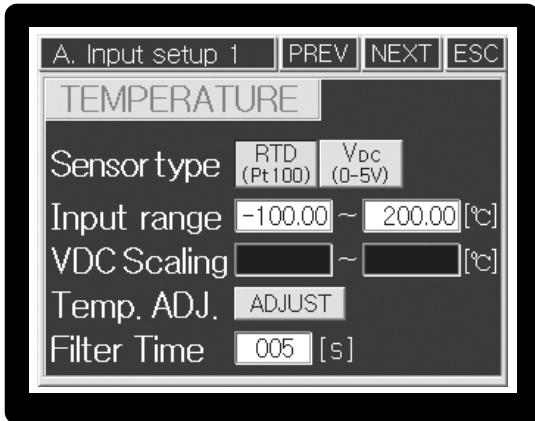

[Fig. 76] Temperature sensor setting screen

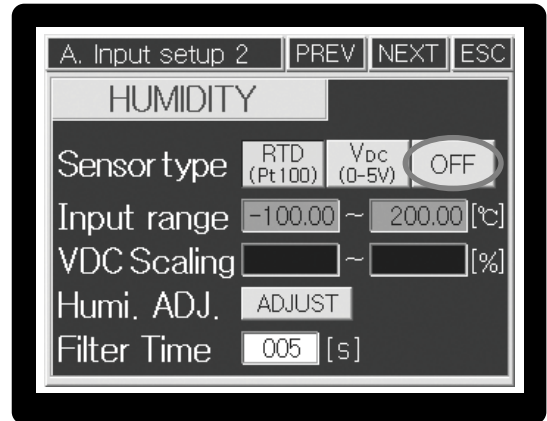

[Fig. 77] Humidity sensor setting screen

(1) Sensor type

Select by the input sensor type. When performing the relative humidity measurement by using the wet/dry method and when sensor for dry and wet is RTD (Pt100 Ω), please select as the **RTD (Pt100)** for sensor type in "temperature sensor related setting" and "humidity sensor related setting." If electrical type humidity sensor (model:EE99) is used then temperature sensor will be considered as RTD (Pt100 Ω) so select the sensor type as **RTD (Pt100)** within the "temperature sensor related setting" and select the sensor type as **Vdc (0-5V)** d.c voltage for "humidity sensor related setting" because output for humidity sensor is 4 – 20 mA. (But, in case of current output sensor, please connect the resistance (less than 250 Ω 1 %) on the external input terminal in parallel.)

Lastly, please select OFF for the humidity sensor type when using as the temperature only mode.

Temperature only display screen In case of using Temperature only display mode, please select humidity sensor type as OFF on the Sensor Input Screen 2 [Fig.77]. This time operation screen will be displayed as Temperature only screen.

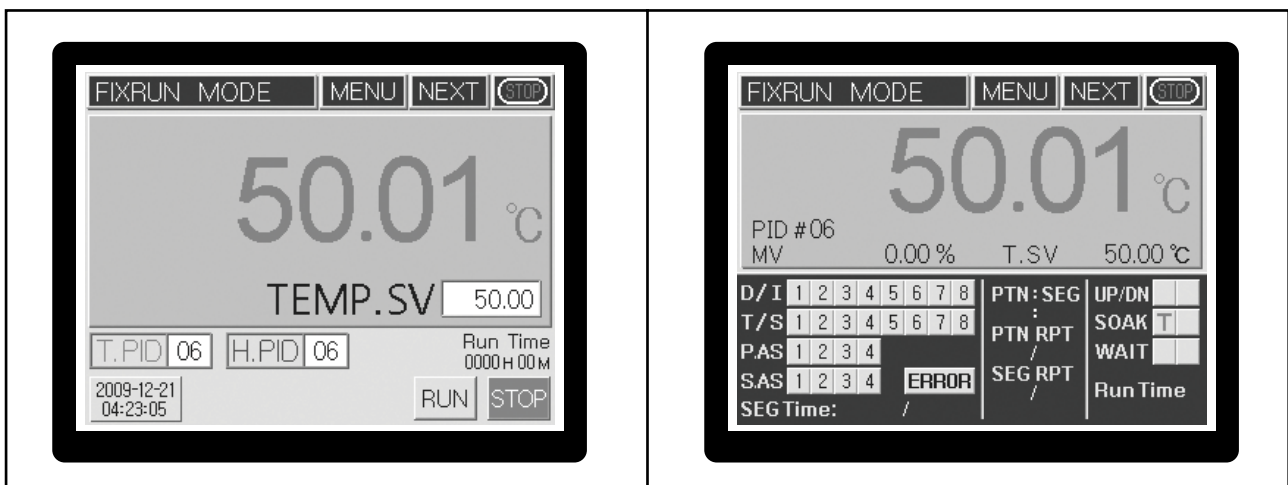

[Fig.78] Temperature only display

(2) Input range

Regarding sensor input range, you can use initial value. The initial setting for temperature value is $-100 \sim 200$ °C and humidity value is $0 \sim 100$ % R.H. If you use electronic humidity sensor (Model # EE99), please set up input range to – V d.c and contact resistance (250 °C 1 % below) to the both of input terminals.

(3) Scale setting

In case of selecting sensor type as , scale setting screen is not activated. That is to say, RTD(Pt 100) is not related to scale setting. In case of , please input proper scale setting value. The setting range is – V. Scale setting range of temperature sensor setting screen – TH500 : $-100 \sim 200$ °C, TH300 : $-100 \sim 500$ °C / Scale setting range of humidity sensor setting screen : $0.0 \sim 100.0$ %

(4) Sensor Bias(Input Bias)

Sensor Bias screen will be displayed when touching Sensor .
Sensor Bias has two methods : OFF–set bias and Section bias.

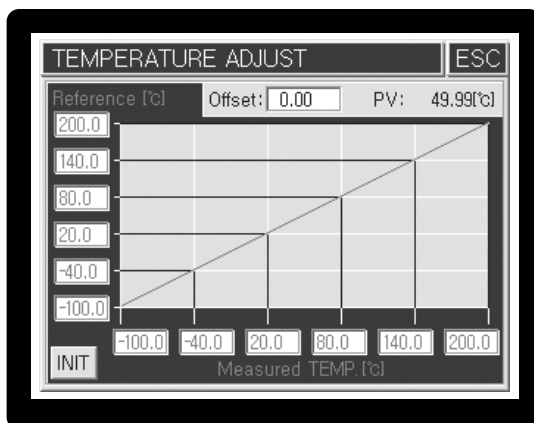

[Fig.79] Temperature Bias

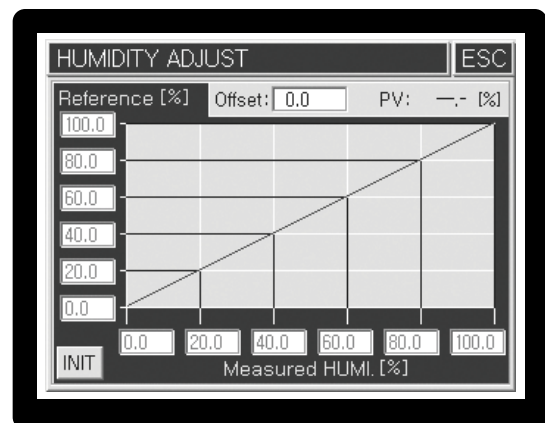

[Fig.80] Humidity Bias

Sensor Bias(Input Bias) corrects deviations caused by many reasons. Horizontal axis means standard temperature or humidity and vertical axis means measured temperature or humidity. Also each value could be changed to any value by touching number. OFF–set bias removes deviations by selecting desired value when measured temperature or humidity value has overall deviations compared to standard value. For example, if measured temperature is 10 °C lower than standard temperature, touch Off–set and change 0.00 to . In this case, measured value will be compensated by 10 °C Section bias is used when compensating deviations per section. In case of standard temperature 80 °C and measured temperature 70 °C, 10 °C compensation of measured temperature is necessary. This time please touch 80 °C and enter 70 in the number plate. After touching , compensation is finished.



- Partial bias can be selected by setting each section in accordance with its use because partial bias aims to change the slope of section.

(5) Filter setting

Filter setting sets the suitable time when process value varies due to the flow of high noise through out the input sensor line.

6.1.2 Sensor Input Setting 3

[Fig 81] Set Dry bulb temperature range and Wet/Dry Input Bias to control humidity.

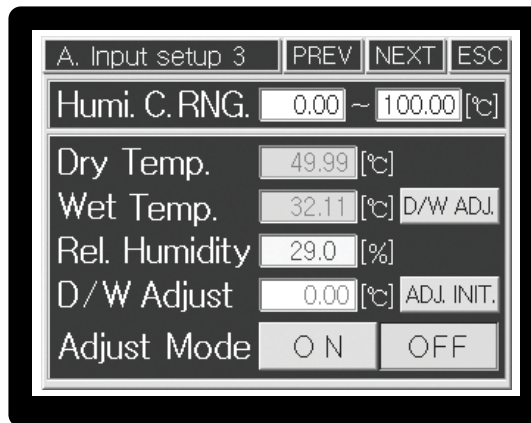

[FIG.81] Sensor Input Setting 3

Humi.C.RNG.	It sets Wet bulb Temperature range. (Initial value : 0 ~ 100 °C) Measured humidity value will not be displayed in case it is beyond its range (—), control output will be OFF.
Dry Temp.	Displays Dry bulb temperature
Wet Temp.	Displays Wet bulb temperature (Gauze have to be removed)
Rel. Humidity	Displays relative humidity (% R.H.)
D/W Adjust	Press Dry/Wet bulb ADJ and it shows the temperature difference between dir bulb and web bulb. It very important to correct Dry/Web bulb because relative humidity measurement is based on the temperature difference between two sensors.
Adjust mode	If you push setting, correction will be started



- Please remove gauze in the web bulb sensor before correction. And also start correction after stabilization of the process value. Please recover gauze after correction

6.1.3 Sensor Input Setting 4

Within the [FIG 82] sensor input setting 4 screen, it sets the temperature setting range, humidity setting range, temperature resolving power (decimal points indication), sensor break detection and operation delay time.

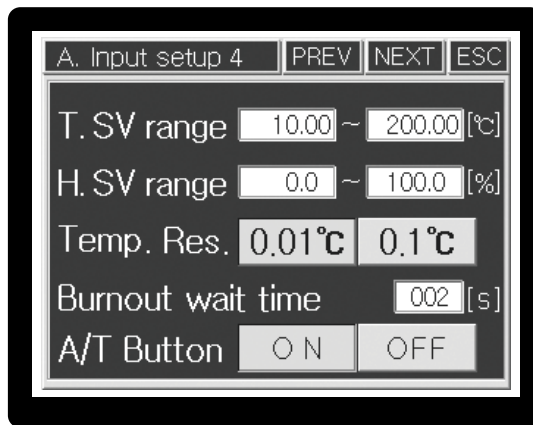

[FIG.82] Sensor Input Setting 4

Setting item	Explanation
T.SV range	In order to prevent mistake of user mistake, the Temperature SV range can be restrictive as much as wanted range.
H.SV range	In order to prevent mistake of user mistake, the humidity SV range can be restrictive as much as wanted range.
Temp. Res.	Temperature process value and SV can select 0.01 °C or 0.1°C
Burnout wait time	After detecting disconnection of sensor, select delayed operation time.
A/T Button	It shows or hides Auto Tuning button in operation screen.

6.2 Control output setting

Control Output Setting screen is consisted of total 4 screens : Temperature control output, Humidity control output, Temperature Retransmission output, Humidity Retransmission output. Move to each screen by touching **NEXT** button.

6.2.1 Control output setting 1

Temperature output type, Output period of SSR, Output direction(Reverse/Forward), Output range could be set up on the Control Output Setting 1 [Fig.83]

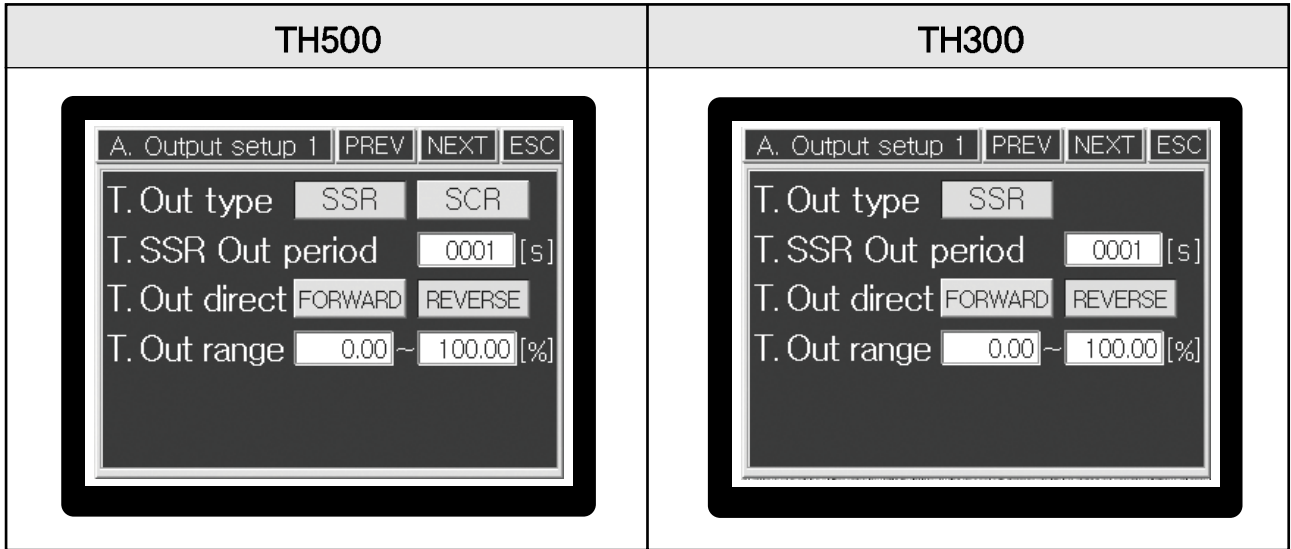

[Fig. 83] Control output setting 1

6.2.2 Control output setting 2

Humidity output type, Output period of SSR, Output direction(Reverse/Forward), Output range could be set up on the Control Output Setting 1 [Fig.84]

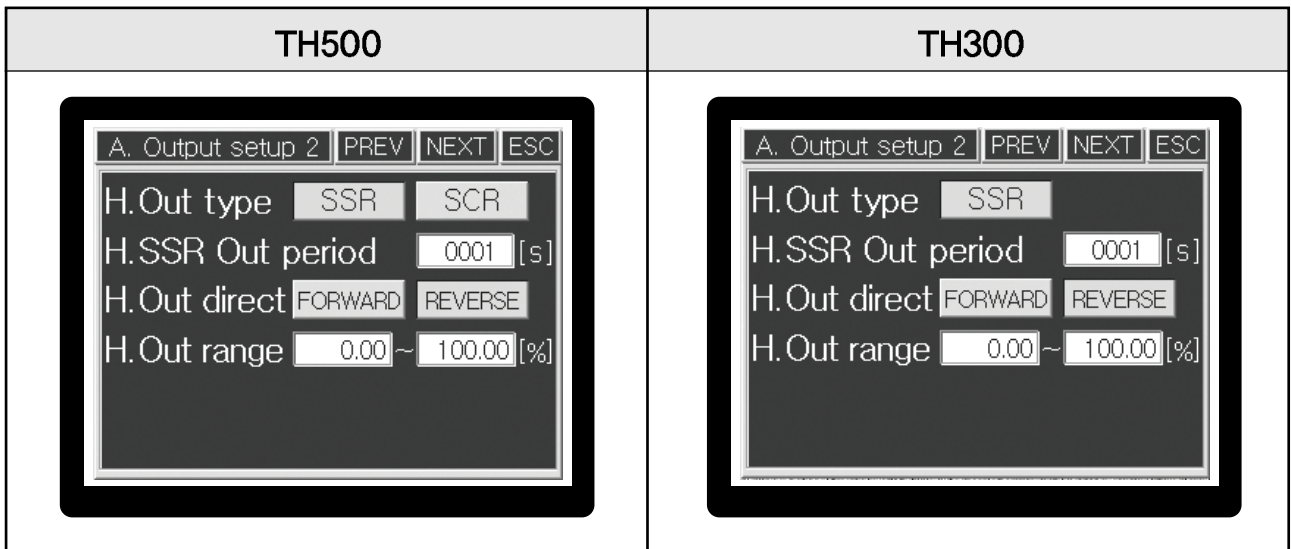

[Fig. 84] Control output setting 2

● Control Output Setting 1 is the same as Control Output Setting 2

T.Out type	Select and use S.S.R or S.C.R (4 – 20 mA d.c). Select according to the equipment (Initial value : S.S.R)
T.SSR out period	You can set up when you select S.S.R output. Output cycle means On/Off working time in the proportional band. (Initial Value : 1 seconds)
T.Out direct	Select cooling control (direct movement) or heating control (inverse movement) (Initial Value : Inverse movement)
T.Out range	You can control output and selection range : -5 %(3.2 mA d.c) . . . 105 %(20.8 mA d.c) (Initial Value : 100 %)

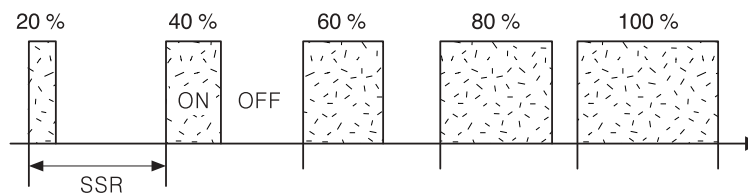

[FIG.85] S.S.R pulse output

Based on SSR pulse output, control output will be ON in a specific time and remaining time will be OFF.

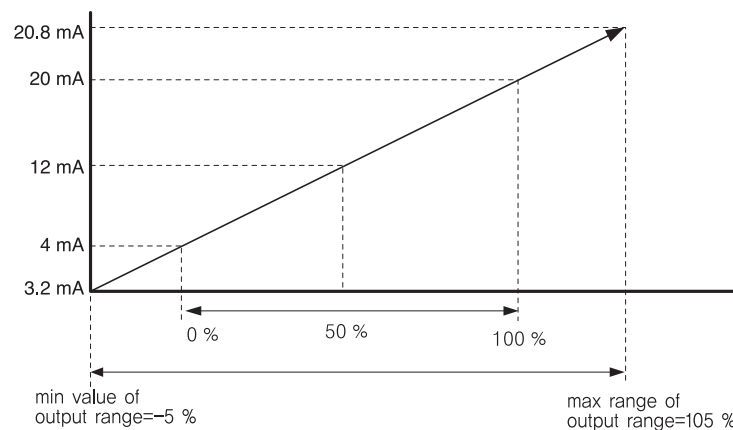

[FIG.86] S.C.R output

In case min value is -5 %, it becomes 3.2 mA d.c output and it becomes 20.8 mA d.c output in case max value is 105 %. The value of control output within its range will be converted into rectilinear figure and output will be done.

6.3 Retransmission output setting

Temperature & Humidity retransmission output can be selected on Control Output Setting screen 3 [Fig. 87] & Control Output Setting screen 4 [Fig. 88].

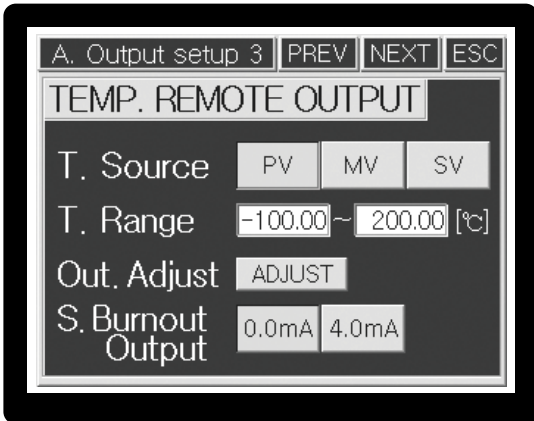

[Fig. 87] Temperature retransmission output setting screen

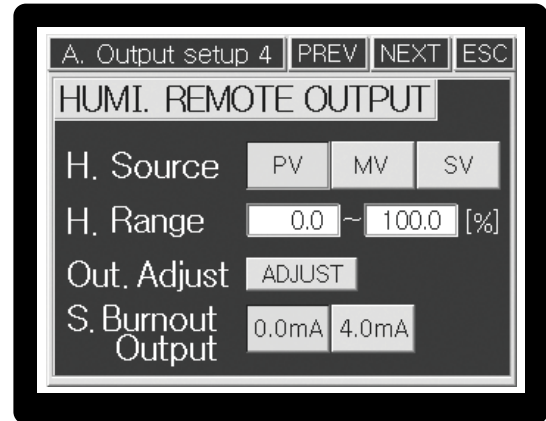

[Fig. 88] Humidity retransmission output setting screen.

※ The contents of Control Output Setting screen 3 & Control Output Setting screen 4 are same.

Setting item	Explanation
T.Source	Select type of RET (Retransmission output) against temperature. It is used as input in the recorder etc. output signal is 4 – 20 mA d.c and select one among PV (Process Value), MV (Manipulated Value), SV (Setting Value).
T.Range	Scale value against temperature output range will be selected 4 – 20 mA d.c But if MV selected, output will be the percentage of setting value against 4 – 20 mA d.c It means if you select 50 %, output will be 12 mA d.c
Out. Adjust	Input Current Bias Value in order to delete deviation. When pressing ADJUST , Temperature retransmission output bias screen[Fig. 89] will be shown up. If output value is different compared to the standard output 50.0, please touch TEST button after setting standard output as 50.0. In this case, output signal which is corresponded to 50.0 will be generated. Please measure this value after inputting this value on the measured output setting screen, please remove TEST button.
S.Burnout Output	between 0.0 mA d.c and 4.0 mA d.c

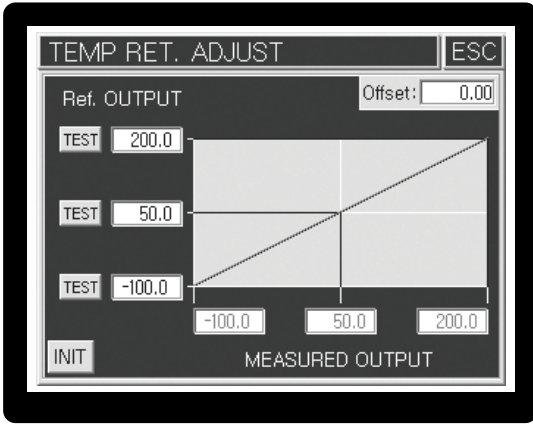

[Fig.89]Temperature retransmission output bias

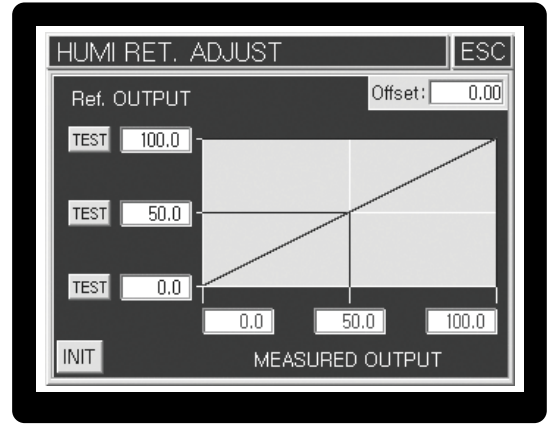

[Fig.90]Humidity retransmission output bias

Button	Contents
Offset	Compensate overall deviations of output.
TEST	Output is activated by set value on the standard output through retransmission output.
INIT	Initialize bias values.

6.4 Inner Signal and Alarm setting

6.4.1 Inner Signal setup

Time Signal is related with segment and Time but Inner Signal is used for signal output of temperature and humidity. So Inner Signal is not related with segment section.

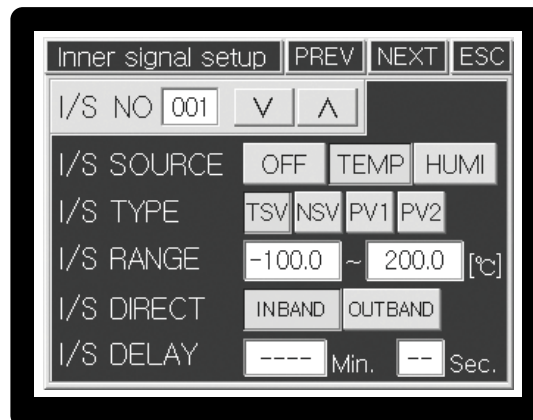

[Fig. 91] Inner signal setup

Setting item	Function
(I/S) Number	Directly input it by pushing Inner Signal number or select it by push <input type="button" value="v"/> <input type="button" value="^"/> button.
(I/S) SOURCE	Select Inner Signal item (Temperature or Humidity)
(I/S) TYPE	TSV (Target Set Value): Operate base on target setting value NSV (Now Set Value): Operate base on current setting value P.V1: Operate base on process value of action range 'L' and 'H'. P.V2: Operate base on process value that are related with setting value and deviation setting value.
(I/S) RANGE	Setting temperature and humidity range of Inner Signal
(I/S) DIRECT	Setting application range of Inner Signal
(I/S) DELAY	Operate delay time of Inner Signal.

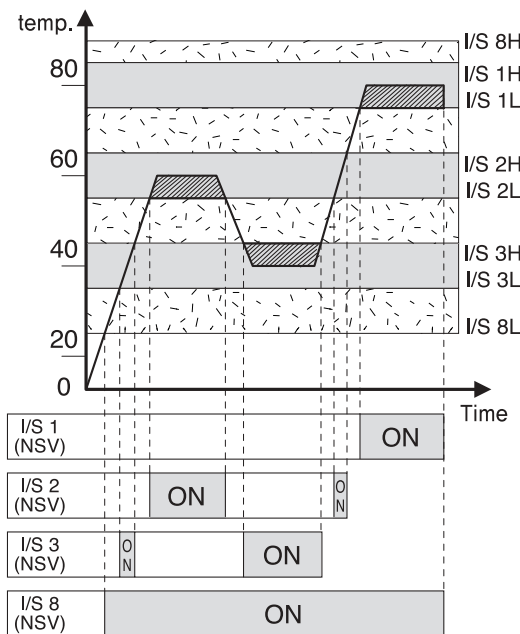

[Fig. 92] Example of Inner Signal setting (NSV)

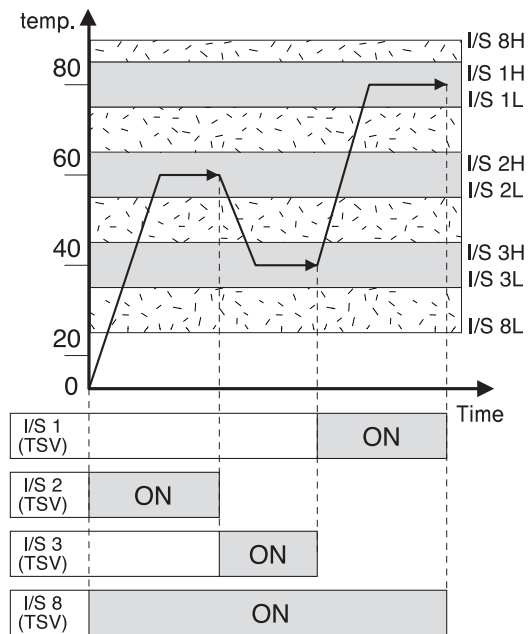

[Fig. 93] Example of Inner Signal setting (TSV)

[Fig. 92] is an example for Inner Signal setting (NSV). Setting Inner Signal 1~3 & 8 for temperature, internal range, NSV, → According to change of Set value (SV), Inner Signal turn ON/OFF. [Fig. 93] is an example for Inner Signal Setting (TSV) Setting Inner Signal 1~3 & 8 for temperature, Internal range, TSV → Base on TSV (Target Set Value), Inner Signal turn ON/OFF / [Fig. 94] is an example for Inner Signal Setting (PV1) Setting Inner Signal 1~3 & 8 for temperature, PV1, Internal range

[Fig. 95] is an example for Inner Signal setting (PV2) Setting Inner Signal 1~3 & 8 for temperature, PV2

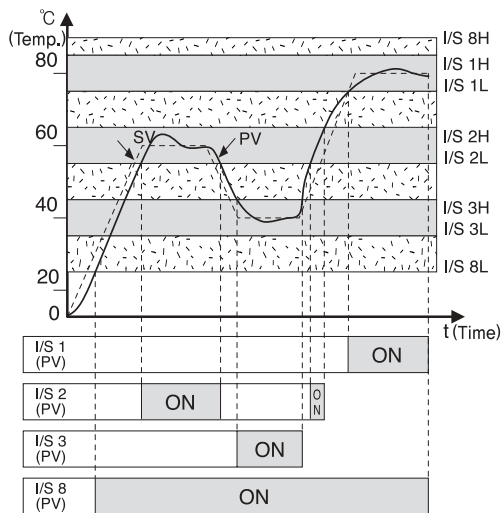

[Fig. 94] Example of Inner Signal setting (PV1)

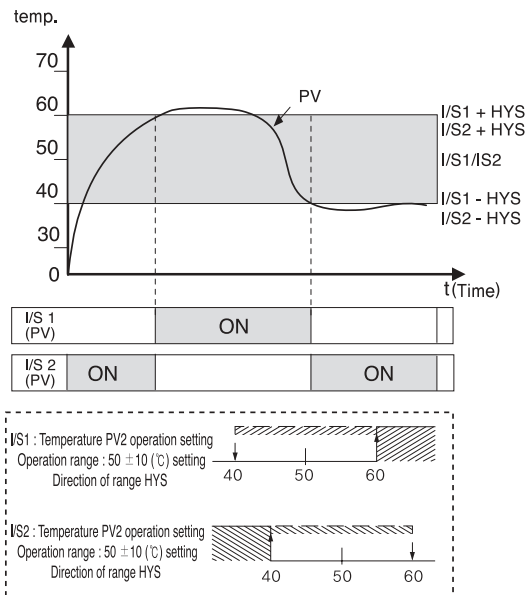

[Fig. 95] Example of Inner Signal setting (PV2)

6.4.2 T ON/OFF Signal

When pressing **INNER SIGNAL/SYS. ALARM** in the System setting menu screen, Inner signal setting screen will be shown up. If you press **NEXT** button T ON/OFF signal setting screen [Fig.96] will be shown up. This screen is a zone setting screen based on temperature and humidity setting values. Each output depend on setting condition could be set up and then used in the D.O Configuration Setting 3 screen.

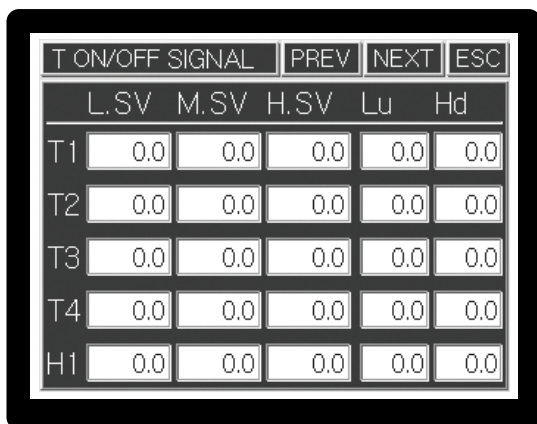

[Fig.96] T ON/OFF Signal Setting Screen

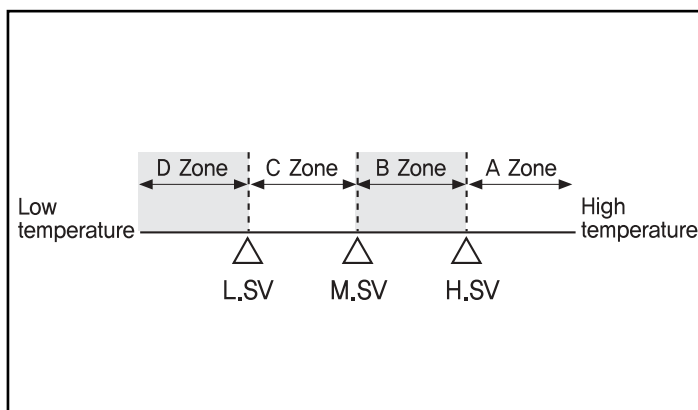

[Fig.97] Section of T ON/OFF zone

Setting item		Function
L.SV	Low set value	Set low setting value
M.SV	Middle set value	Set middle setting value
H.SV	High set value	Set high setting value
Lu	Low limit deviation setting	Set Low limit deviation setting
Hd	High limit deviation setting	Set High limit deviation setting
T1~T4	Temperature 1~4	Temperature zone setting per group(4 groups)
H1	Humidity 1	Humidity zone setting (1 group)

Same as [Fig.97], range is divided by four zones (A,B,C,D) by means of L.SV, M.SV, H.SV. Its setting condition is $L.SV < M.SV < H.SV$

Zone	Description
A zone ($PV \geq H.SV$)	Always OFF regardless of bias(deviation)
B zone ($M.SV \leq PV < H.SV$)	1) $Hd=0$ (Always OFF regardless of bias) 2) $Hd \neq 0$ (Refer to Fig.98) OFF : $PV < SV + Hd$ ON : $PV \geq SV + Hd$
C zone ($L.SV \leq PV < M.SV$)	1) $Lu=0$ (Always OFF regardless of bias) 2) $Lu \neq 0$ (Refer to Fig.99) OFF : $PV \leq SV - Lu$ ON : $PV > SV - Lu$
D zone ($PV < L.SV$)	Always OFF regardless of bias

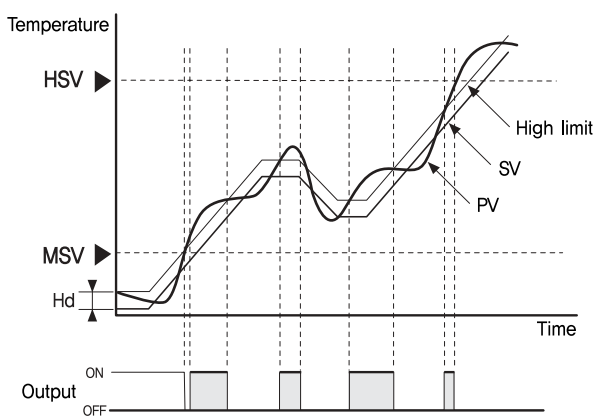

[Fig.98] Zone setting

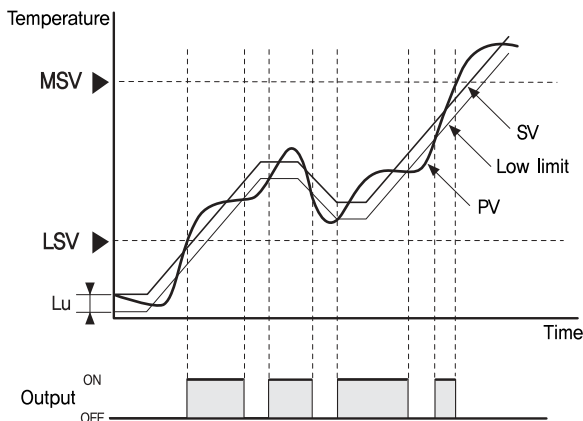

[Fig.99] Zone setting

6.4.3 System alarm setup

This is a setting screen for Temperature and Humidity alarm.

If you push on the system setup menu screen, Inner signal setup screen will be displayed. And then, if you push , System alarm setting screen will be displayed [Fig. 100].

1. Establish a standard for alarm setting value among Temperature and Humidity
2. If you push alarm code select button, System alarm code setting will be displayed as [Fig. 101].
3. Push , button and select proper alarm type as [Fig. 100].
4. If you want to cancel selected code, please push on the left side.
5. And then set, alarm value and Hysteresis.

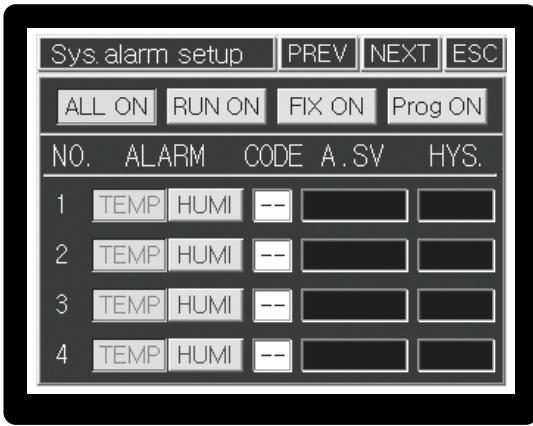

[FIG.100] System alarm setup screen

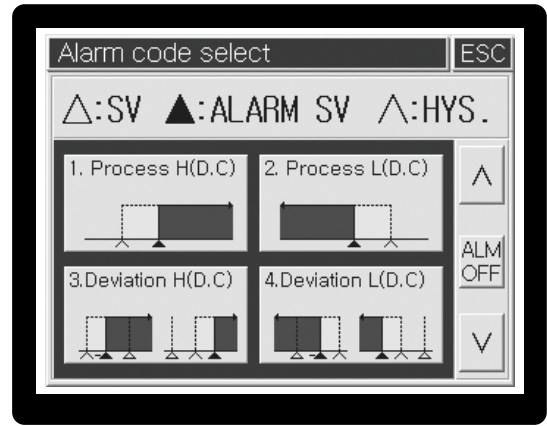

[FIG.101] System alarm code setting

4 buttons in the system alarm setting screen [FIG 100] on the above select the operation condition (Operation condition related to the set value) and information is as follows.

Setting item	Description
ALL ON	All ways turn on alarm
RUN ON	Maintain alarm on operation
FIX ON	Maintain alarm on fixed control operation
Prog ON	Maintain alarm on program control operation

6.5 P.I.D Setting

The TH500 / 300 is equipped with the total 16 PID ZONES. As shown in the chart below, the four temperature zones and four humidity zones are combined with each other, so you can control the temperature and humidity with the optimized PID value. You are free to change the zone boundary of temperature and humidity.

Temp. Zone \ Humi. Zone	$-100 \leq \text{Temp. SV} \leq \text{TZ}_1$	$\text{TZ}_1 < \text{Temp. SV} \leq \text{TZ}_2$	$\text{TZ}_2 < \text{Temp. SV} \leq \text{TZ}_3$	$\text{TZ}_3 < \text{Temp. SV} \leq \text{TZ}_4$
$0 \leq \text{Humi. SV} \leq \text{HZ}_1$	Zone 1	Zone 2	Zone 3	Zone 4
$\text{HZ}_1 < \text{Humi. SV} \leq \text{HZ}_2$	Zone 5	Zone 6	Zone 7	Zone 8
$\text{HZ}_2 < \text{Humi. SV} \leq \text{HZ}_3$	Zone 9	Zone 10	Zone 11	Zone 12
$\text{HZ}_3 < \text{Humi. SV} \leq \text{HZ}_4$	Zone 13	Zone 14	Zone 15	Zone 16

※ TZ : Temp.Zone, HZ : Humi.Zone

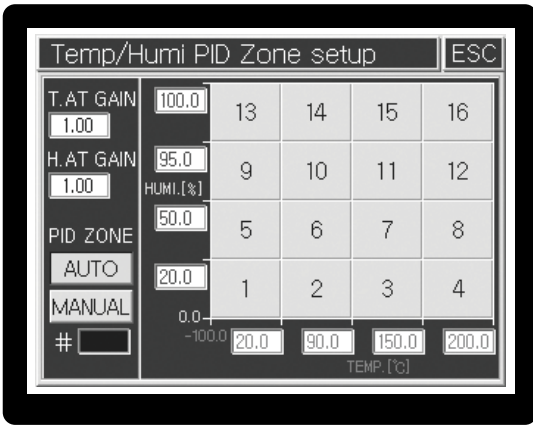

[Fig.102] Temp. & Humi P.I.D Zone Setting

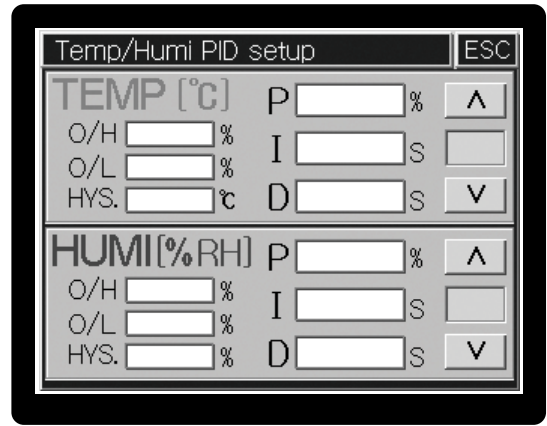

[Fig. 103] Temp. & Humi P.I.D Setting

The PID ZONE / buttons on the bottom in the left side of the PID setting screen [Fig. 102] is the button for the automatic & the manual. For example, choosing if you do auto-tuning of temp. at 80 °C, Temp. PID value is applied as the same with temp. in the zone 3,7,11 & zone 15. and if you do auto-tuning of Humi. at 75%, Humi. P.I.D value is applied in the zone 11. In case of Manual mode, kindly refer to just SV in the zone set according to the .

When you check the value of P.I.D or input to collect directly, you can set P.I.D value of Moving Temp. & Humi. in P.I.D setting screen [Fig. 103] by pushing Zone button wanted in the [Fig. 102]. However it is not possible to set HYS(Hysteresis) setting screen cause it is not activated as a grey color. In order to set it, set [P] value as [0]. In this case, it's possible to set it because ON/OFF control is selected when set [P] value as [0] if you want to use ON/OFF control only, set P.I.D zone number as [0]. It is possible to set each P.I.D zone's output range. Please input Max output range in the O/H, Min output range in the O/L. If you want to use only ON/OFF control, you can put the number of P.I.D zone into Temp. & Humi. A/T GAIN on the above in the left side is a constant value which is applied to the each item of P.I.D during P.I.D carries out on operation. The setting range is from 0.0 to 10.0 (Initial value : 1.00). It is used that optimize P.I.D numerical value automatically operated after P.I.D Auto-tuning more delicate manually. According to the variation of A/T GAIN value, the variation of Control feature is same with [Fig. 104].

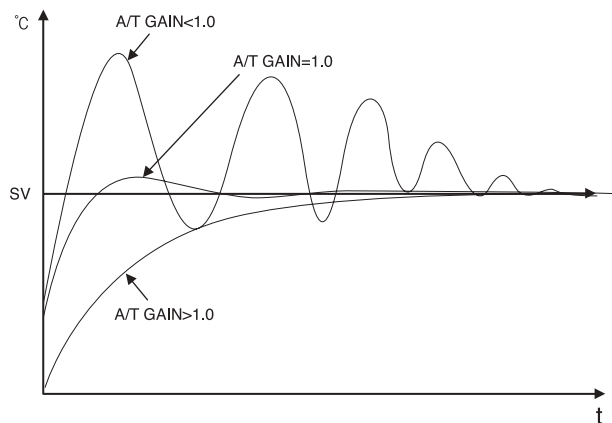

[Fig. 104] Variation characteristic control by controlling Auto-tuning GAIN(PV)

● Temp · Humidity PID

Name	Description	Range
P (Proportional)	Set up proportional band. When proportional band is wide, the time to reach to setting value is slow because of small quantity of control output regarding the Offset When proportional band is narrow, the time to reach to setting value is fast because of high quantity of control output . But, if it is too narrow, hunting is appeared.	(0 ~ 100) % (TH500) Temp (0 ~ 600) °C (TH300) Humidity (0 ~ 200) % (TH300)
I (Integral)	Set up integral time. Offset is appeared with using only the propoirtional control. In this way, deviation is reduced with an integral operation and if an integral time is too long, it is modified late and when integral time is short, hunting is appeared again and gain.	(0 ~ 6,000) s
D (Derivative)	Set up a derivative time. As a modification operation regarding rapid temperature change, it has a control output which is proportional to temperature change's slope When derivative time is longer, correction is getting better.	(0 ~ 6,000) s
HYS.(Hysteresis)	Set up a hysteresis while controlling ON/OFF or Autotuning	Refer specification
O/H	Set up a maximum value of output range	0.01 ~ 100,00
O/L	Set up a minimum value of output range	0.00 ~ 99,99

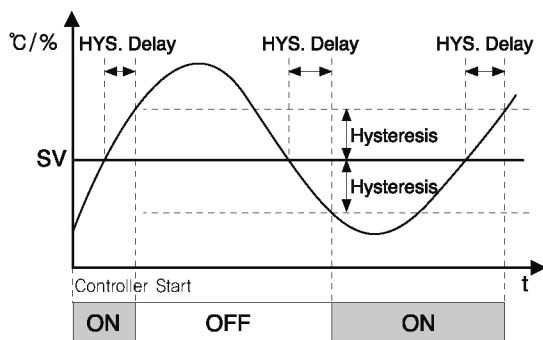

[FIG.105] ON/OFF control

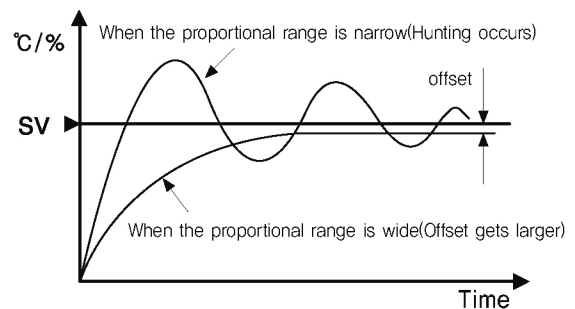

[FIG.106] Proportional control (P control)

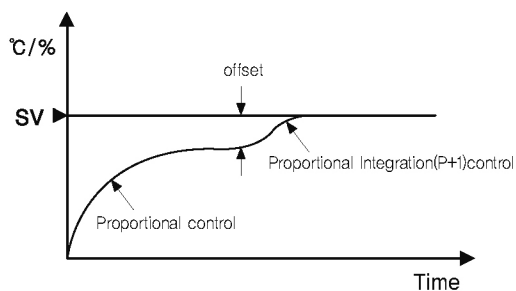

[FIG.107] Proportion (P) and Proportional Integration (P+I) control

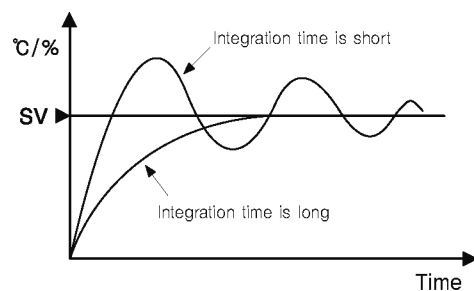

[FIG.108] Proportional Integration (P+I) control

6.6 D.I Configuration Setting

D.I(Digital Input) is consisted of 3 screens .TH500 has 8 points of D.I and TH300 has 4 point of D.I (Active Low)

6.6.1 D.I Setting 1

You can assign three operation functions (RUN/STOP, STEP, HOLD) which is related to basic operation function in the D.I Setting 1[Fig. 109]. User can set up HIGH/LOW operation to these three operation functions. As LEVEL input, RUN/STOP and HOLD input should maintain their level continuously. Because STEP operation is EDGE input, it operates one time according to its setting in case of H→L or L→H. You should enter H and L continuously in order to keep on STEP operation.

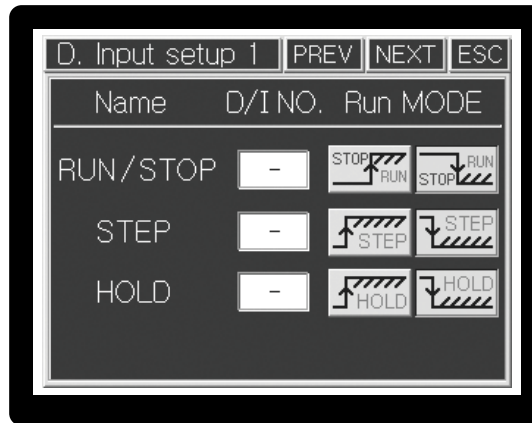

[FIG. 109] D/I setting 1



- Overlapping assignment of D.I number is not available in the inputs of RUN/STOP, STEP, HOLD operation function. Also when input of STEP and HOLD come is at the same time, it ignores STEP input and it handles HOLD input only.
- Regardless of control action(Running or Stop), external D.I is always displayed and handled internally according to its input status.

Name	Function
RUN / STOP (LEVEL Input)	Start or end the assigned D/I input signal according to the operation mode (H/L) set.
STEP (EDGE Input)	In case of running in program control mode, perform the STEP operation (go to the next SEG. by force) for the assigned D/I input signal according to the operation mode (H/L) set.
HOLD (LEVEL Input)	In case of running in program control mode, perform the HOLD operation (hold the current SEG. operation unlimitedly regardless of set time) for the assigned D/I input signal according to the operation mode (H/L) set.

6.6.2 D.I Setting 2

It is possible for user to use each D.I name or Error name directly by using the combination of KOR/ENG/NUM/SIGN. When touching D.I name screen( mark), number input keypad will be shown up. By using keyboard change button, set the name per each D.I number.

The name which is set in D.I setting 2 will be displayed in the operation history screen in case it makes an error through D.I.

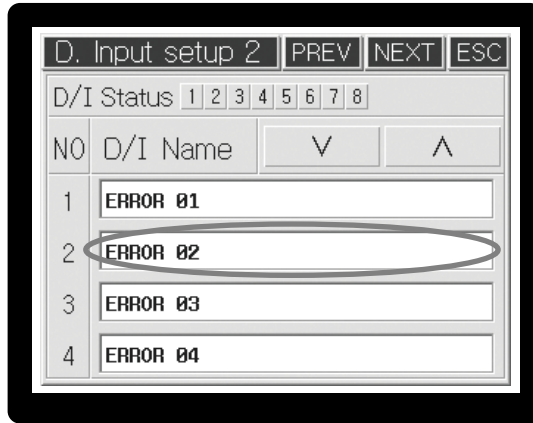



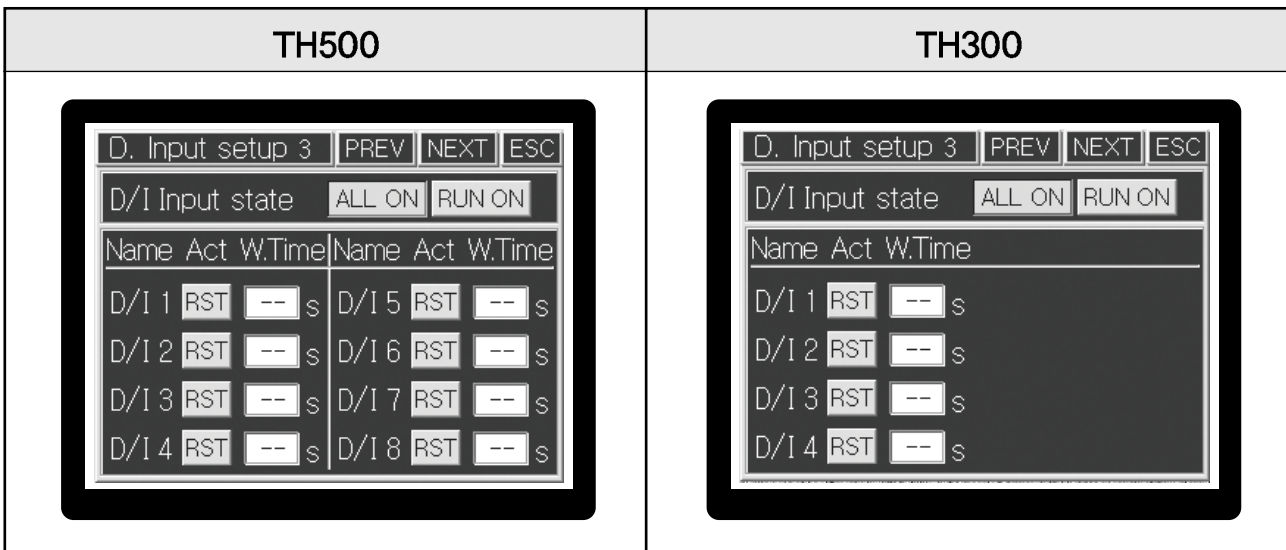

[Fig.110] D.I Setting 2

6.6.3 D.I Setting 3

It is a common case that D.I has external error input. Therefore sometimes it is necessary to stop system control not by RUN/STOP but by D.I. In D.I Setting 3 [Fig.111], it is possible to set System Stop against the remaining D.I numbers except D.I numbers allocated to operation function (RUN/STOP, STEP, HOLD). D.I number When touching **RST** button, Waiting Time Input screen will be activated. When selecting Waiting Delay time, system will be finished after passing waiting delay time.



[Fig. 111] D.I Setting 3

Setting item		Explanation
D.I Input status		In case of Power ON – Always ON regardless of operation condition
		In case of Power ON – ON during operation
ACT		In case of DI input, it is the button for setting System Reset(END). Only if you press this button, the DI waiting time will be valid.
W.Time		On the status of System RESET touched, it resets (END) the system after passing DI waiting time.

6.7 D.O Configuration Setting

The D.O configuration setting refers to the screen for assigning the various signals within the system to RELAY output and O.C output. Here, the signals assigned and connected are displayed through the actual terminal. The D.O assignment is allowed to be redundant except special cases, so it is necessary to assign and enter the RELAY and O.C carefully.

When outputboard-3 is used in TH500, Relay13 ~ Relay20 can be assigned through O/C1 ~ O/C8.

(Example: if Relay15 is desired to be used, please set O/C3 for Relay15.)

6.7.1 D.O Configuration Setting 1(Output allocation about the innersignal)

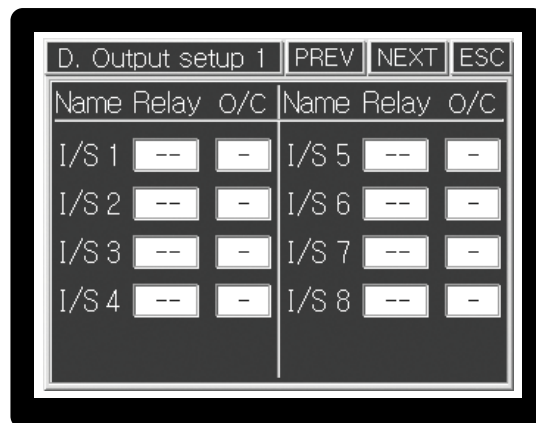

[FIG.112] D.O Configuration Setting 1(Inner Signal)

The D.O configuration setting 1, 2 [Fig. 112, 113] refers to the screen that assigns Inner Signal and Time Signal to RELAY output and O.C output respectively.

6.7.2 D.O Configuration Setting 2 (Output assignment against Time Signal)

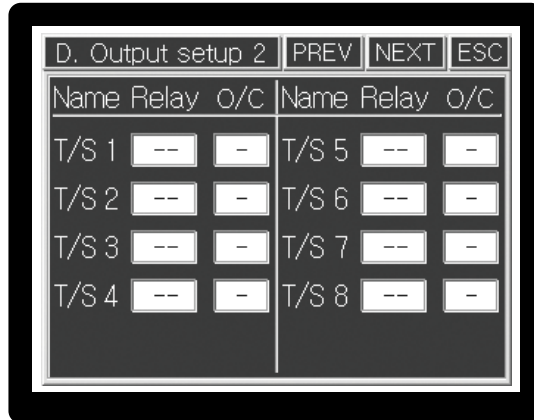

[Fig.113] D.O Configuration Setting 2

6.7.3 D.O Configuration Setting 3

It is a screen for Output assignment against T ON/OFF Signal Setting [Fig.96].

This screen is a zone assignment by means of temperature and humidity setting values. Each output according to setting condition could be set and used in the D.O Configuration Setting 3 screen. It will be ON after passing setting time and setting time is applied only to the first ON time.

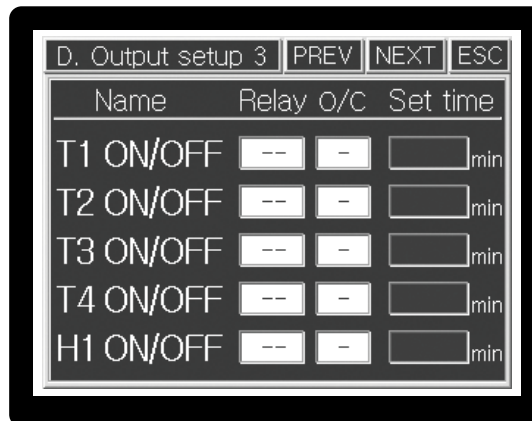

[FIG.114] D.O Configuration Setting 3

6.7.4 D.O Configuration Setting 4 / Setting 5

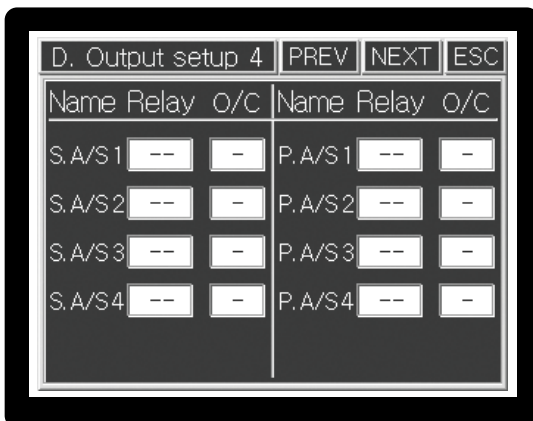

[FIG.115] D.O Configuration Setting 4

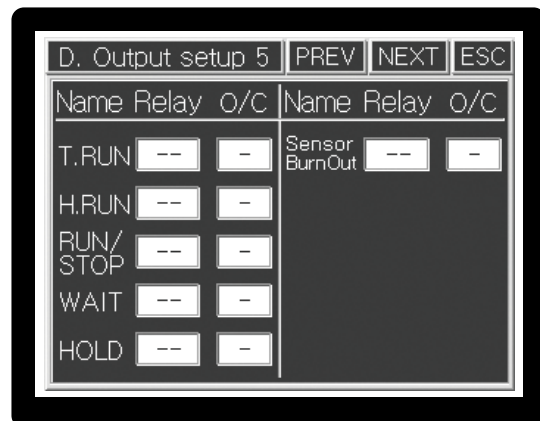

[FIG.116] D.O Configuration Setting 5

D.O Configuration Setting 4,5[Fig.115 & Fig116] is screens that functions such as alarm are allocated to real relay output and open collector output.

Setting item	Explanation
S.Alarm 1~ 4	Assign System Alarm Output 1 ~ 4
P.Alarm 1~ 4	Assign Pattern Alarm Output 1 ~ 4

Setting item	Explanation
T.RUN	Output assignment when controlling temperature
H.RUN	Output assignment when controlling humidity
RUN/STOP	Output assignment under RUN/STOP
WAIT	Output assignment for WAIT operation
HOLD	Output assignment for HOLD operation
Sensor Burnout	Output assignment in case of sensor disconnection

6.7.5 D.O Configuration Setting 6

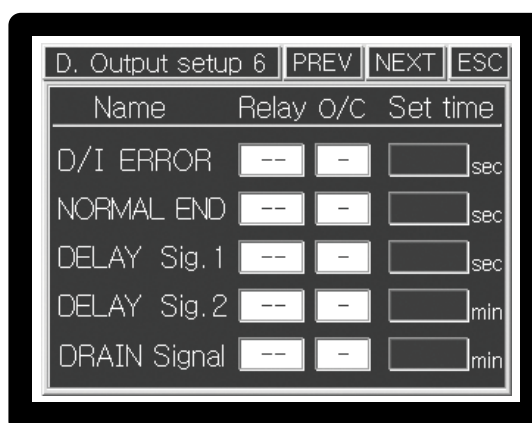

[FIG.117] D.O Configuration Setting 6

Setting item	Explanation
D.I ERROR (sec)	In case of D.I input, its output becomes ON for a setting time. IF RUN/STOP, STEP and HOLD function input is set, its D.I will be not included.
NORMAL END(sec)	Once program control ends, its output becomes ON for a setting time
DELAY Sig.1 (sec)	After doing output of I.S(Inner Signal)#1,its output becomes ON after delaying for a setting time.
DELAY Sig. 2(min)	After doing output of I.S(Inner Signal)#1,its output becomes ON after delaying for a setting time. (Delay signal 2 is only available in the middle of performing Delay signal 1
DRAIN Signal (min)	When selecting Humidity Set Value (H.SV) as "0" : stop controlling humidity, relevant output will be on during set time.

6.7.6 D.O Configuration Setting 7

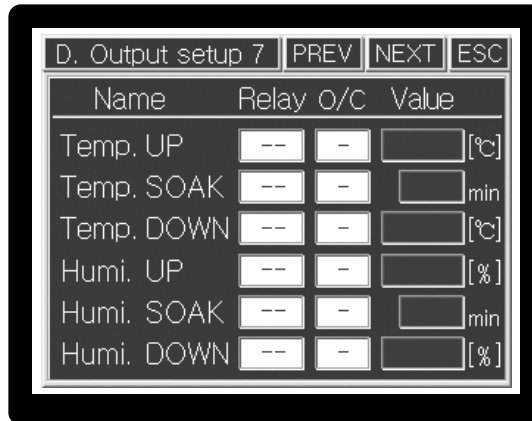

[FIG.118] D.O Configuration Setting 7

D.O Configuration setting 7 [FIG 118] is used when turning ON the output within the increase/maintain/decrease interval of each of temperature/humidity set value (SV). Each set input value of setting lists operates same as [FIG 119]

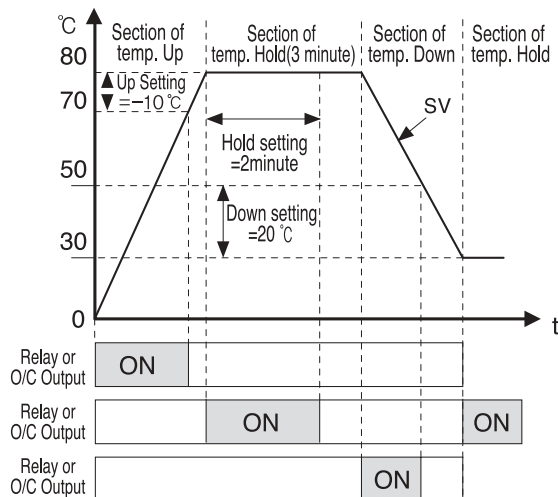

[Fig.119] Output by temperature UP/HOLD/DOWN setting

It shows an example of displaying either Relay or O/C output corresponding to the temperature UP/HOLD/DOWN setting of temperature and humidity SV when operating Program Control. Ex : section of temp.UP(-10 °C), section of temp.HOLD(2 Min) and section of temp DOWN(+20°C) It indicates the ON timing under the assigned Relay or O/C output.

Setting item	Explanation
Temp. & Humi. Up	Input the minus value of Temp. & Humi. in the target of setting value
Temp. & Humi. Down	Input the plus value of Temp. & Humi. in the target of setting value
Temp. & Humi. SOAK	Input the holding time of Relay or O.C output within segment time

6.8 Communication Setting

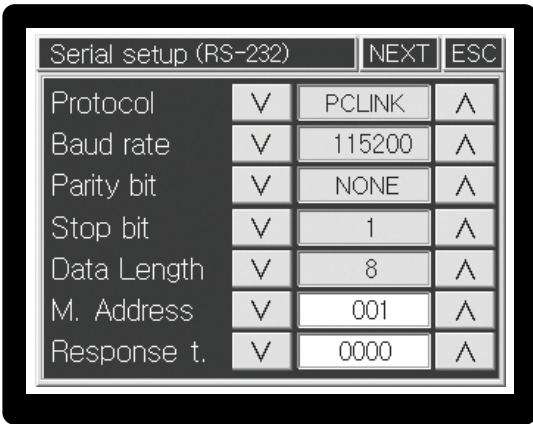

[FIG.120] Communication Parameter Setting (RS232)

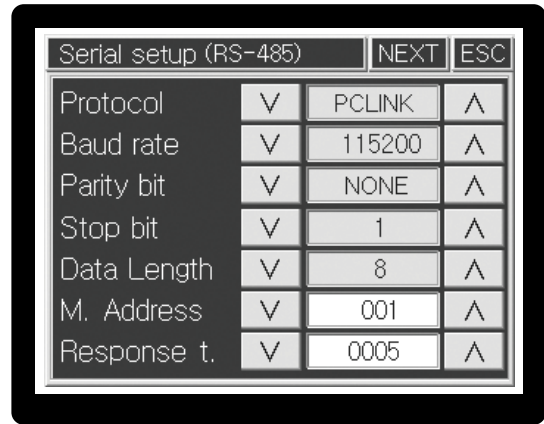

[FIG.121] Communication Protocol (RS422/485)

The communication setting refers to the screen for setting either RS232 or RS422/485 parameters to communicate with the device that supports PC or other serials. You can change it with the Up/Down arrow buttons, and can enter the local device number and response time by selecting the input box on your own. Because RS232C/485 communication supports 4 lines (RX+, RX-, TX+, TX-) in hardware and the type of Half-Duplex in software, if you want high speed communication, you should connect into 4 lines. In other case, if you want a simple connection, you can use 2 lines by connecting RX+ with TX+ & do RX- with TX-. If you want a simple connection by connecting 4 lines, you can use 2 lines by connecting RX+ with TX+ & doing RX- with TX-.

● Communication Parameter Setting

Name	Function	Range
Protocol	Select the communication protocol. PCLINK operates by following the format which is assigned by Hanyoung Nux and MODBUS-RTU operates by following the standard format.	PCLINK /PCLINK+CRC MODBUS-RTU
Baud rate	Set the communication speed (BPS). You can select TH500 – one out of 9600/19200/38400/57600/115200 TH300 – one out of 9600/19200/38400	9600 ~ 115,200 9600 ~ 38400
Parity bit	Set the parity bit.	NONE / EVEN / ODD
Stop bit	Set the stop bit.	1 / 2
Date length	Set the data length.	5, 6, 7, 8
M. Address	Set the device number to be used in the system. It is used as its own device number when forming the serial network.	1 ~ 999
Response t. [ms]	Select the inter-Byte delay time when sending data. Used when the target equipment to receive runs at a low speed.	(0 ~ 1,000) ms

6.9 ETC Setting



[FIG.122] ETC Setup 1

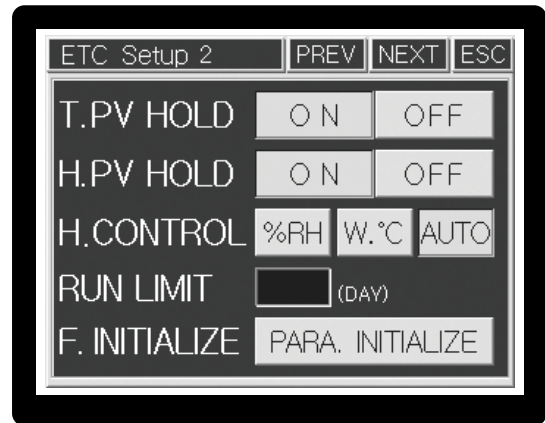

[FIG.123] ETC Setup 2

6.9.1 ETC Setup 1

Name	Function
Language	Select a system language. It supports Korean and English.
Password	Change a system password. You should enter your password in the unit of four numbers and do so twice for confirmation.
User information	Enter the user information to indicate upon the initial system activation. You can enter 29 letters of English/Number/Sign or 14 letters of Korean on one line.

6.9.2 ETC Setup 2

Name	Function
T.PV HOLD	When selecting T.PV HOLD, It holds a minute temperature hunting
H.PV HOLD	When selecting H.PV HOLD, It holds a minute humidity hunting
H.CONTROL	<input type="button" value="%RH"/> Control by R.H
	<input type="button" value="W.°C"/> Control by humidity of wet bulb ※ It prevents excessive status and it has a rapid safety.
	<input type="button" value="AUTO"/> Standard control by inner setting
RUN LIMIT	Set a available operation date of this equipment.
F. INITIALIZE	Setting values turn into the original values of manufacturer.

7 Simple Example

HANYOUNG NUX is Temperature Humidity Controller (Model: TH500 / 300) is consisted of Operation screen, Operation Setting screen, System Setting screen. You can select structural elements in the System Setting. System installation company such as environment test chamber manufacturer etc already finished the system setting when they taking it's product out of warehouse. So users do not have to do system setting additionally. Users can set up humidity-temperature simply through Operation Setting.

7.1 Input related setting

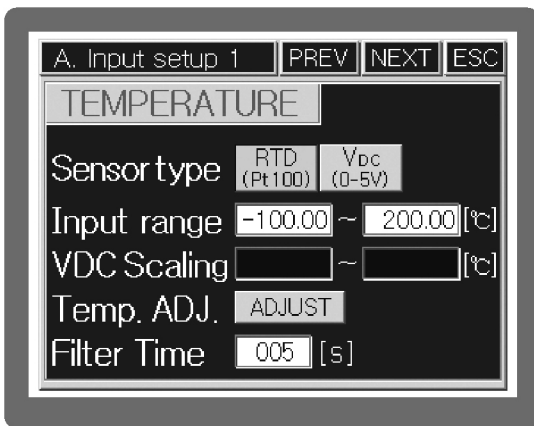

[FIG.124] Sensor Input Setting 1

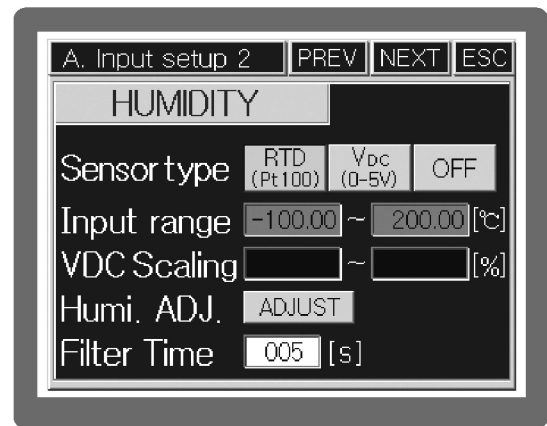

[FIG.125] Sensor Input Setting 2

7.1.1 Sensor Input Setting

Setting item	Explanation
Sensor Type	Set up according to input sensor type. If sensor type is a dry or web bulb respectively and RTD (Pt100) type, select RTD. If you use electronic humidity sensor (Our Model EE99), you should set up temperature sensor as RTD (Pt100) and humidity sensor as Vdc (0-5V) ※ Select humidity sensor type as OFF in case it needs temperature control only.
Input Range	Limit the input range of sensor. Generally, it is fine with using the initial value but, input range of temperature is -100 ~ 200 (TH500), -100 ~ 500 (TH300) and input range of humidity is in % RH. If you are using the electric humidity sensor (model EE99), set up the input range to (1-5)V and connect metallic film resistor (250 ohms 1% less) to both ends of desktop humidity sensor input terminal
VDC Scaling	When selecting V d.c, set up suitable scale. In case of 1-5 V input and display range: 0 ~ 100, set up scaling setting as 0 ~ 100.
Temp. ADJ.	When touching ADJUST in the [Fig.124, Fig.125]. [Fig.79] & [Fig.80] will be displayed.
Filter Time	Low Pass Filter selects suitable time when processed value is chattering due to inflowing of noise through input sensor line.

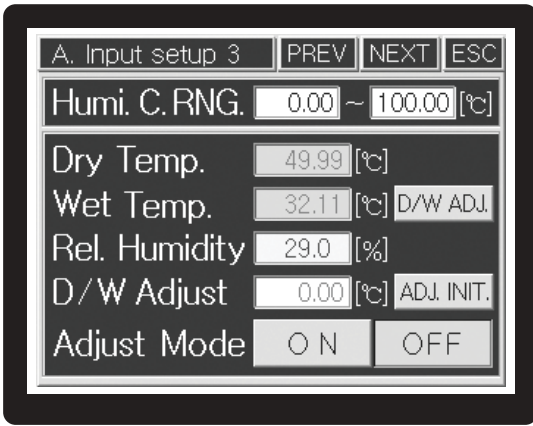

[FIG.126] Dry - Humidity sensor correction screen

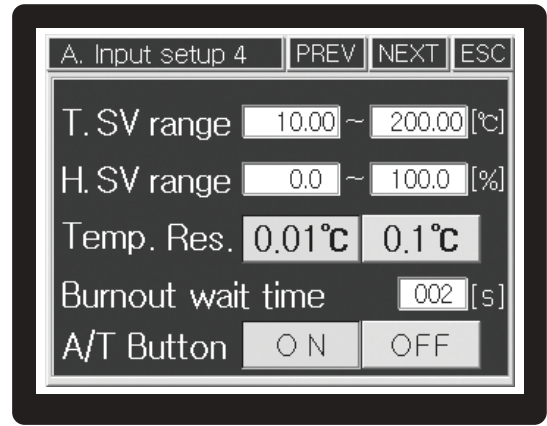

[FIG.127] Range setting screen

7.1.2 Correct Dry/Web bulb sensor

Setting item	Explanation
Humi.C.RNG.	Set up dry/web bulb temperature range.
Dry Temp.	Displays temperature of dry bulb temp.
Wet Temp	Displays temperature of wet bulb temp.(removal gauze)
Rel. Humidity	Displays relative humidity (% R.H.)
D/W Adjust	Press Dry/Wet Bulb ADJ and it shows the temperature difference between dry bulb & wet bulb. It very important to correct Dry/Wet Bulb because relative humidity measurement is based on the temp. difference between two sensors.
Adjust Mode	Correction will be performed when pressing it.
ADJ. INIT	보정 전의 값으로 초기화 됩니다.



- Before correction, please remove gauze in the wet bulb sensor and put into correction mode when measurement value of dry/wet bulb is stabilized.

7.1.3 Range Setting

T.SV range	In order to prevent mistake of user input setting, Input temp.range when restricting temp. SV within its desired range.
H.SV range	In order to prevent mistake of user input setting, Input humidity range when restricting humidity. SV within its desired range.
Temp. Res.	Select Temp. process value and SV as 0.01 °C or 0.1 °C.
Burnout wait time	Set up delayed action time after detecting sensor loof brake.
A/T Button	It shows or hides Auto Tuning button in Operation Screen.

7.2 Setting Output

7.2.1 Control Output Setting

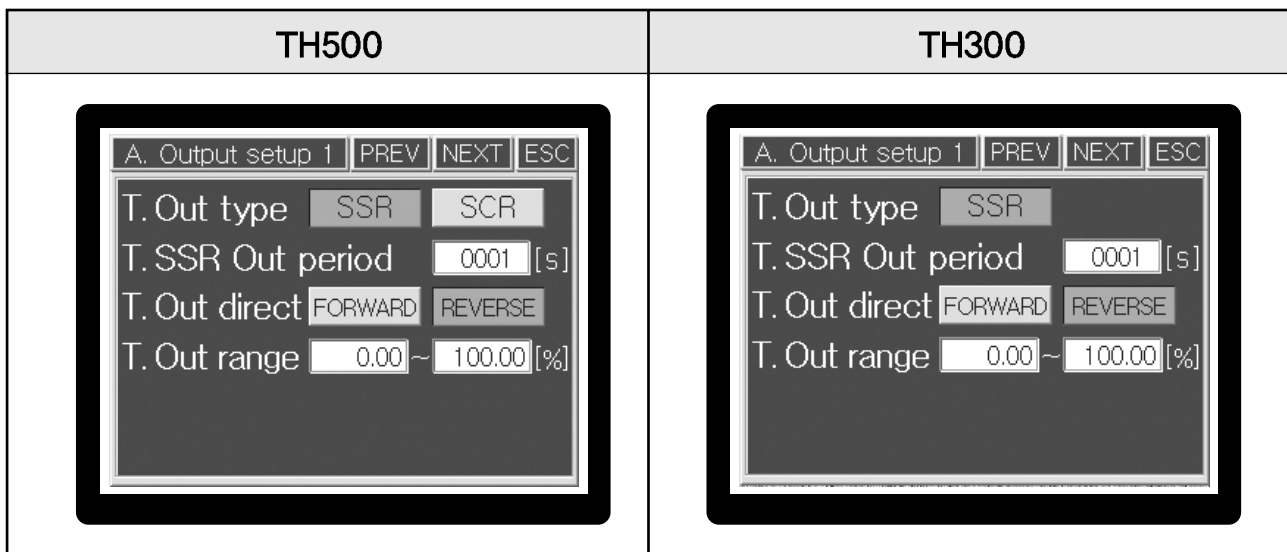

[FIG.128] Control output setting 1

T.Out type	TH500	S.S.R or S.C.R(4 – 20 mA) could be used as a control output (Initial value : S.S.R)
	TH300	Control output is S.S.R only.
T.SSR Out period		You can set up when you select S.S.R output. Output cycle means ON/OFF operation time in the proportional band.(Initial value : 1 sec)
T.Out direct		Select cooling control(direct operation) or heating control (Reverse operation). (Initial value : Reverse operation)
T.Out range		Output could be controlled and its range is -5.00% (3.2 mA) ~ 105.00% (20.8 mA) (Initial value : 0.00 ~ 100.00%)

7.2.2 Retransmission Output Setting (Control Output Setting 3, Control Output Setting 4)

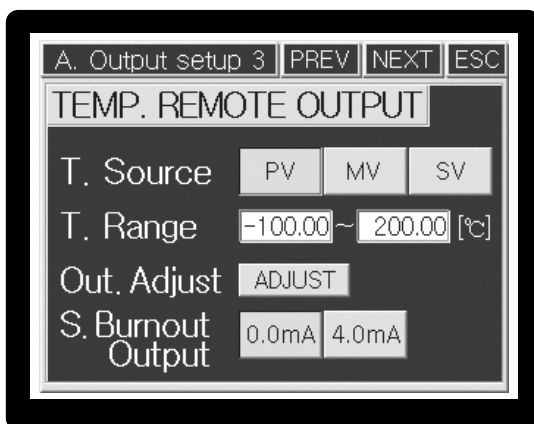

[Fig.129] Temp.Retranmission Output Setting

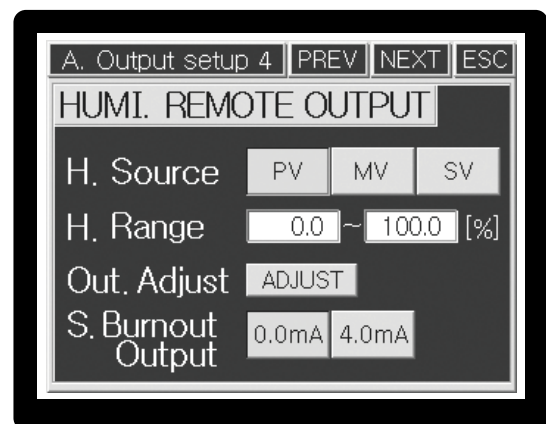

[Fig.130] Humidity Retranmission Output Setting

Setting item	Explanation
T.Source	Select the type of RET(Retransmission output) against temperature. It is used as an input in the recorder etc. Output signal is 4 – 20 mA d.c and select one among PV(Process Value),MV(Manipulated Value),SV(Setting Value).
T.Range	Scale value against temp. output range will be selected 4 – 20 mA d.c. But if MV is selected, output will be the percentage of setting value against 4 – 20 mA d.c It means that output will be 12 mA d.c if you select 50 %.
Out. Adjust	Input Bias value in order to remove deviation value of retransmission output. When touching <input type="button" value="ADJUST"/> ,[Fig.89] & [Fig.90] will be displayed.
S.Burnout output	In case of sensor loof brake, select between 0.0 mA d.c and 4.0 mA d.c

※ Humidity setting method is the same as Temperature setting method.

7.3 Inner Signal Set

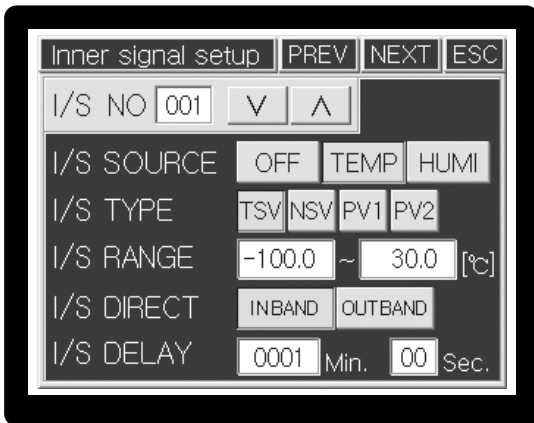

[FIG.131] Inner Signal Set

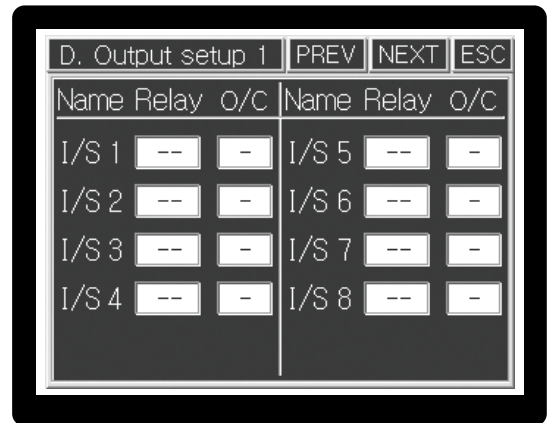

[FIG.132] D.O Output setup1

When controlling refrigerator and dehumidifier separately by external switch, it can be used generally with input-output setting only. But in case it needs to control (On/Off) refrigerator & dehumidifier under desired temperature and humidity, it's convenient to use Inner Signal. Please refer to the below example, select setting and use it.

(Example 1) Control refrigerator & dehumidifier automatically

Inner Signal No.	Signal Subject	Signal Type & Range	Delayed Time	Output Allocation(D.O)
I/S No.1	Temperature Range : -100 ~ 30 °C	Type : TSV Direction : Within Range	1 minute	Connect refrigerator to 5th Relay
I/S No.2	Subject : Humidity Range : 0 ~ 70 %	Type : TSV Direction : Within Range	10 seconds	Connect dehumidifier to 6th Relay

(Example 2) Control refrigerator 1,2 & dehumidifier automatically (Use I/S 1~3)

Inner Signal No	Signal Subject	Signal Type & Range	Delayed Time	Output Allocation(D.O)
I/S No. 1	Temperature Range : -100 ~ 30 °C	Type : TSV Direction : Within Range	1 minute	Connect 1st refrigerator to 5th Relay
I/S No. 2	Subject : humidity Range : 0 ~ 70 %	Type : TSV Direction : Within Range	10 seconds	Connect dehumidifier to 6th Relay
I/S No. 3	Subject : Temperature Range : -100 ~ 50 °C	Type : TSV Direction : Within Range	5 seconds	Connect 2nd refrigerator to 7th Relay



• You have to select temperature range of refrigerator according to its specification. If you set up too high temperature, it may cause malfunction of refrigerator.

7.4 Fix Control

7.4.1 Select how to operate

In order to operate Fix Control, firstly select operating method as fix control. Press **MENU** button on the operation screen and move to function setting menu screen. Press **FUNC. SET** button and it moves to operation setting 1 screen. On this screen, press **FIXRUN** button and select fix control. And then, press **RUN SCREEN** button two times and move to operation screen 1 in the fix control.

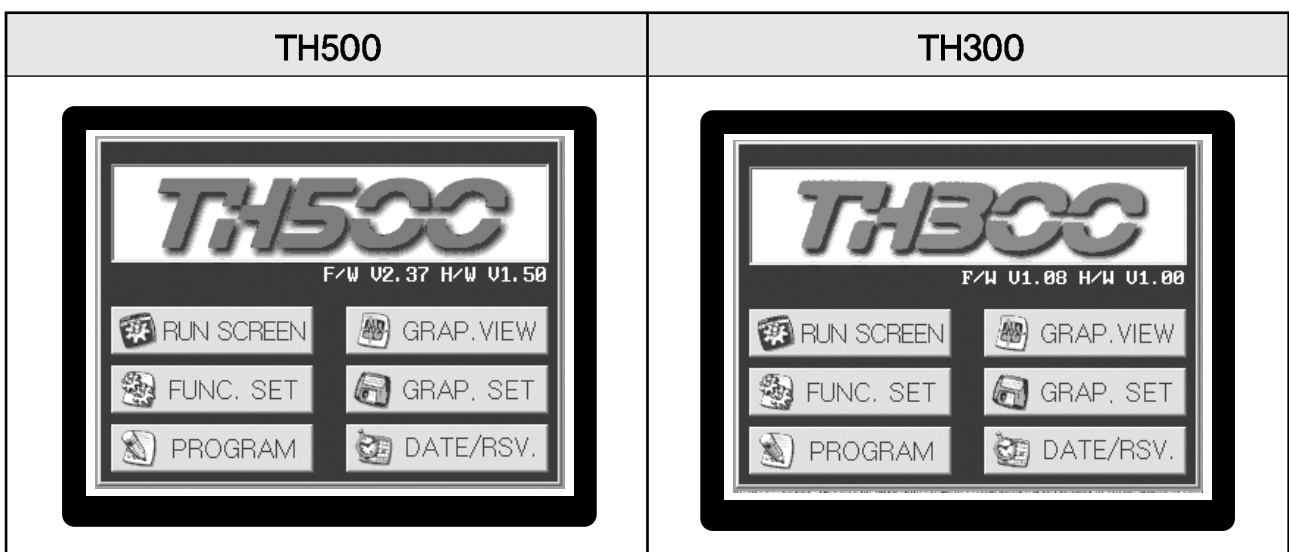

[FIG.133] Function setting menu

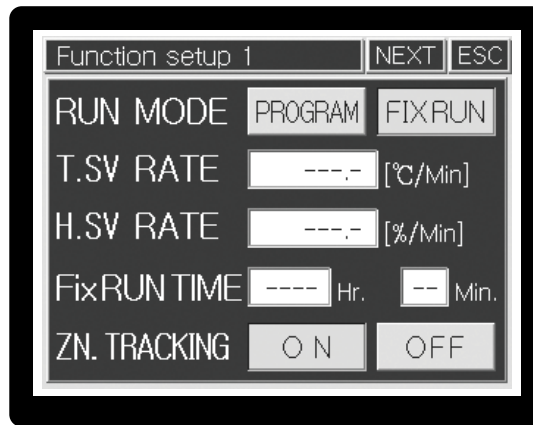

[FIG.134] Function setup 1

7.4.2 Temperature & Humidity Control Value Setting

Press temp. & humidity setting and set up desired setting value. (After set up number, please press **ENT** button in order to finish setting finally.) and it will be back to the 1st Operation Stop Screen of Fix Control [Fig. 135]

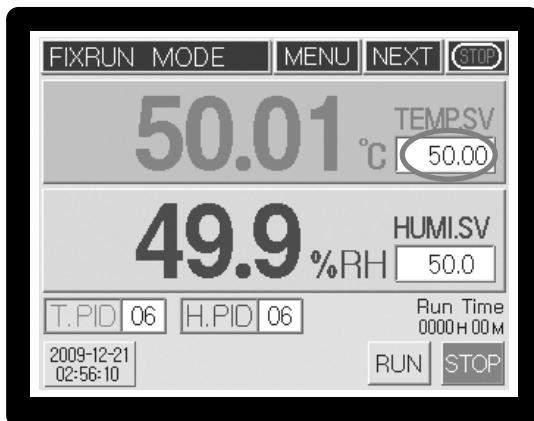

[FIG.135] Fix control 1st operation stop

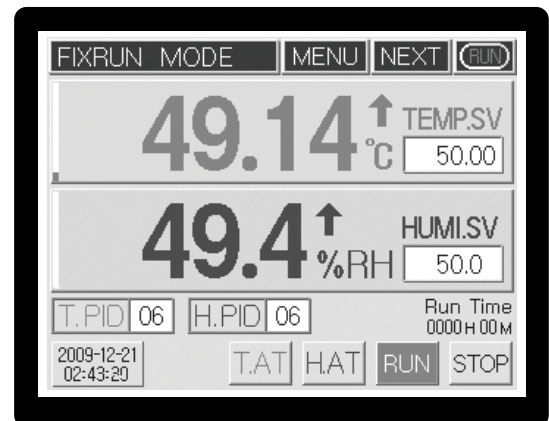

[FIG.136] Fix control 1st operation

7.4.3 Operate and STOP of Fix Control

In the Fix control 1st operation stop screen [Fix. 135], you can check its operation by pressing **RUN** button. Press **YES** button leads it to start operation. If you press **STOP** button in the [Fix. 136], operation will be stopped when pressing **YES** button in the displayed processing verification screen.

7.4.4 Start Auto Tuning

Although it starts fix control operation according to users' setting value, if you do not perform Auto Tuning, P.I.D control will be applied in accordance with its initial value at the delivery of goods. Therefore it will be better to perform Auto Tuning in order to get good control performance. To start Auto Tuning, press Auto Tuning button **T.AT** at the bottom of picture [Fig.136]. When T.AT button flickering, it shows that Auto Tuning is being performed. After Auto Tuning finished, Auto Tuning values will be set up automatically and it stops flickering. Same as temperature Auto Tuning **T.AT** perform auto tuning of humidity by pressing **H.AT** button.

7.5 Programmable Control

7.5.1 Selection of Program Control

Firstly select operation method as a program control in order to perform program control. Press **MENU** button under the status of operation screen and move to function setting main screen. After pressing **FUNC. SET** button, it moves to function setup 1 screen. On this screen, press **PROGRAM** button and select program control.



[FIG.137] Function setup 1

7.5.2 Program Pattern Setting

Press **PROGRAM** button in the program setting menu screen, it displays program setup screen [Fig. 138]. Under this screen, select number 1 pattern by pressing pattern number setting window. Press window of temp.setting value, humidity setting value, operating time and then set up relevant segments.

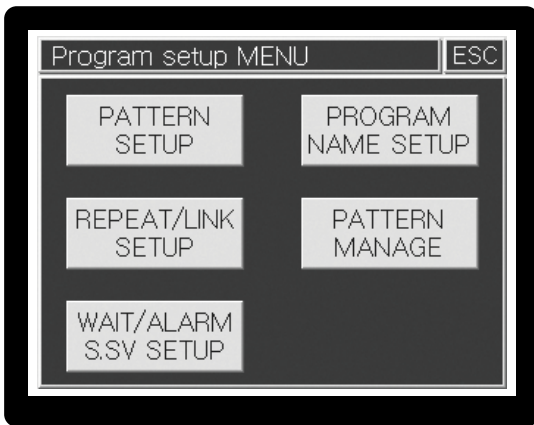

[FIG.138] Program setup menu

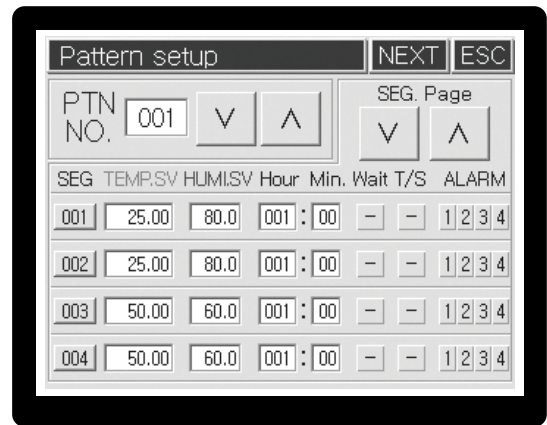

[FIG.139] Program pattern setting

Explanation of Program Pattern Setting Screen

Operating Seg.	Contents of setting	Remark
SEG.No.001	Under the Temp 25 °C, Humidity 80% set up temp. & humidity segment for one minute.	Consider connected pattern as ne and repeat it infinitely
SEG.No.002	Under the Temp 25 °C, Humidity 80% set up temp. & humidity maintenance segment for one minute.	
SEG.No.003	Under the Temp 50 °C, Humidity 60%, temp. rise & humidity fall for one minute.	
SEG.No.004	Under the Temp 50 °C, Humidity 60%, temp. rise & humidity fall for one minute.	
SEG.No.005	Under the Temp 75 °C, Humidity 40% set up temp rise & humidity fall segment for one minute.	
SEG.No.006	Under the Temp 75 °C, Humidity 40% set up temp. & humidity maintenance segment for one minute.	

Explanation of Program Pattern Setting Screen.

Setting item	Explanation	Range
PTN NO.	Input pattern no. directly or select it by using <input type="button" value="v"/> <input type="button" value="^"/> button	1 ~ 100 Pattern
SEG. Page MENU	Press Segment Page Shifting button(<input type="button" value="v"/> <input type="button" value="^"/>) and it moves to 4 segment per each shifting	
TEMP.SV	Press setting screen and set up setting value of temperature of the segment.	TH500 (-100 ~ 200) °C TH300 (-100 ~ 500) °C
Humi.SV	Press setting screen and set up setting value of humidity of the segment.	(0 ~ 100) %
Hour/Min	Set up operation time of the segment	0 ~ 255hours and 59minutes
Wait	Select function of Standby Operation which was set up in the Standby Operation Setting Screen.	ON/OFF
T.S	Select Time Signal which works at the segment	
Alarm	Among 4 Alarms which was set up in the Patter Alarm Setting Screen, select operation respectively. Pattern Alarm Selection Screen [Fig. 48]	1~4 respectively ON/OFF

7.5.3 Operate and stop of program control

Set the connection pattern as 1 (own number) within the pattern repetition/connection setting [FIG 140] screen. Input the each of pattern number and segment number in the program start pattern and start segment setting unit within pattern of program control operation stop [FIG 141] screen and press the **RUN** button then program control operation will be started. In order to stop the program control operation, press the **STOP** button on the right-bottom of the program control operation [FIG 142] screen then program control operation will be stopped.

When operating the program control, the displaying screen will be same as the program control operation [FIG 142], program control status indicating screen [FIG 143] and graph displaying [FIG 144] screen.

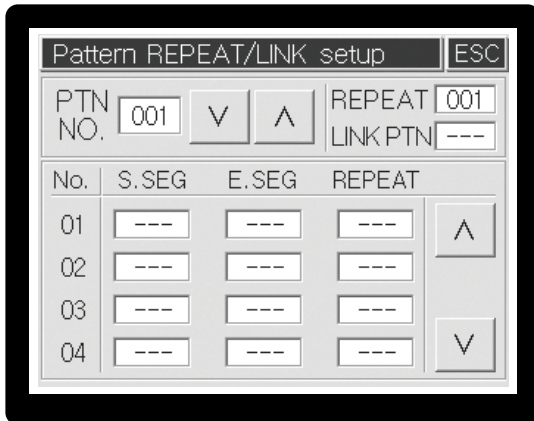

[FIG.140] Pattern repeat / Connection setting screen

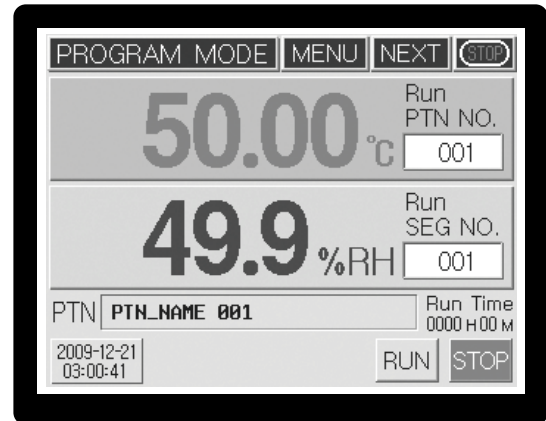

[FIG.141] Program control 1st operation stop screen

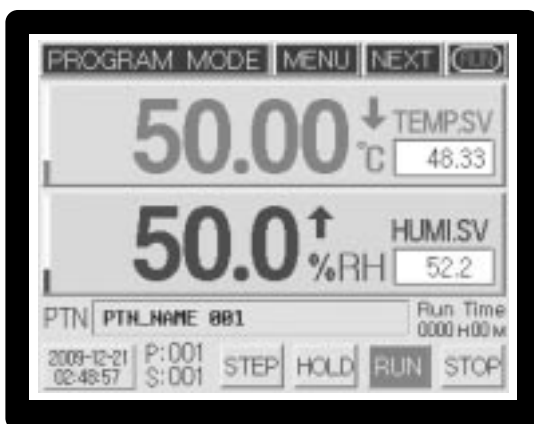

[FIG.142] Program control 1st operation screen

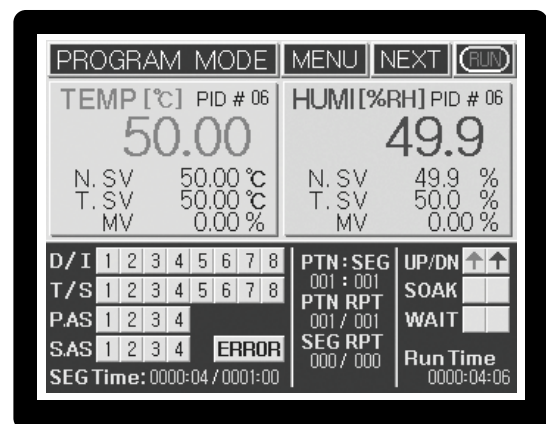

[FIG.143] Program control 2nd operation screen

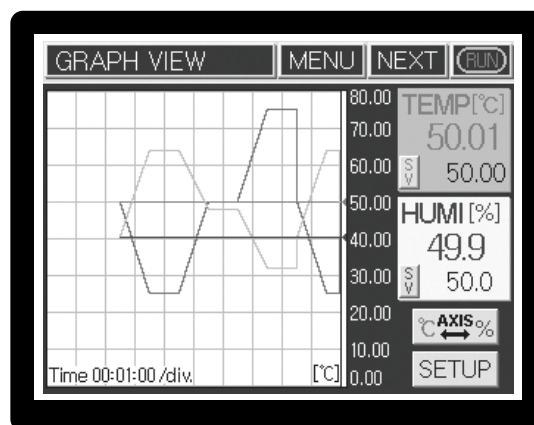

[FIG.144] Graph display screen

8 Specification

8.1 Input

Model		TH500	TH300
Input	R.T.D	R.T.D(Resistance Temperature Detector) : Pt100Ω IEC 751	
	VDC	0 - 5 V d.c ※ In case of using Digital Temperature Sensor (Example:EE99), please connect resistance 250 Ω in parallel on the exterior	
	Sampling cycle	500 ms	
Measurable range	Temperature	-100.0 ~ 200.0 °C	-100.0 ~ 500.0 °C
	Humidity	0.0 ~ 100.0 % R.H.	
Accuracy	Temperature	± 0.1 % of F.S	± 0.2 % of F.S
	Humidity	± 2 % of F.S	
Contact Input(D.I)		8 points(1a 8 points, 2 COM)	4 points(1a 4 points, 1 COM)

8.2 Output

Model		TH500	TH300
Control Output	S.S.R	ON : 24 V d.c OFF : Less than 0.1 V d.c Pulse voltage(More than load resistance 800 Ω) Cycle time : 1 ~ 1,000 sec	
	Current Output(S.C.R)	4 - 20 mA d.c (1 - 5 V) (Load resistance : Less than 600 Ω)	S.C.R is not available
Retransmission Output	Temperature	4 - 20 mA d.c (Load resistance : Less than 600 Ω)	
	Humidity	PV/MV/SV(Internal selection)	
	Resolution	Around 8,000 (4 mA - 20 mA)	Around 7,000 (4 mA - 20 mA)
	Renewal Time	500 ms	
Digital Output (D.O)	Relay	12 points(1c 4 points, 1a 8 points)	8 points (1a 8 points)
		N.O : 30 V d.c 5 A, 250 V a.c : 5 A N.C : 30 V d.c 1 A, 250 V a.c : 2 A	
	Transistor	8 points (2 COM)	4 points(1 COM)
		24 V d.c 300 mA max (Open Collector)	

8.3 Communication

Model		TH500	TH300
적용규격		EIA-RS232C, RS485/422, USB V1.1	EIA-RS232C, RS485/422
max connection	RS232C	1 : 1	
	RS485/422	max 32 devices (master included) ※address : 1 ~ 999	
Communication type	RS232C	Full duplex	
	RS485/422	2 wire type, 4 wire type : Half-duplex	2 wire type, Half-duplex
Synchronizing system	RS232,485/422	asynchronous type	
Communication distance	USB V1.1	approx. within 1 m	
	RS232C	approx. within 10 m	
	RS485/422	approx. within 1.2 km	
Communication speed	USB V1.1	approx. 1 M bps	
	RS232,485/422	9600/19200/38400/ 57600/115200 bps	9600/19200/38400 bps
Data length	RS232,485/422	7 / 8 bits	
Parity bit	RS232,485/422	NONE / EVEN / ODD	
Stop bit	RS232,485/422	1 / 2 bit(s)	
Protocol	USB V1.1	Bulk Mode	
	RS232,485/422	PCLINK / PCLINK+CRC / MODBUS-RTU	
Response delay time	RS232,485/422	(0 - 999) ms	

※ In case of Model TH300, USB V1.1 is not correspond with it.

8.4 Power Supply

Model	TH500	TH300
Power supply voltage	100 - 240 V a.c (Change rate of voltage : ±10%)	
Frequency	50 - 60 Hz	
Power consumption	20 VA max	10 VA max
Insulation Resistance	More than 500 V d.c 20 M Ω Power supply terminal - exterior case, Input terminal - exterior case	More than 500 V d.c 10 M Ω Power supply terminal - exterior box, Input terminal - exterior box
Dielectric Strength	2500 V a.c 50 - 60 Hz : Power supply terminal - exterior case(F/G : Frame Ground), Input terminal - exterior case (F/G : Frame Ground), Input terminal - Input terminal	
External power supply	24V d.c 18 W max (I/O Board)	Not applied

8.5 Functions

Model		TH500	TH300	
Input	Bias(Deviation)	Temp. : -100.00 ~ 100.00 (°C) Humidity : -100.0 ~ 100.0 (% R.H)		
	Dry · Wet sensor Bias	After removing gauze from wet sensor, correct the difference between dry and wet sensor.		
	Scaling	V d.c : Input scale in accordance with conversion range		
	LPF	2 ~ 180 sec	1 ~ 180 sec	
	Detection of sensor disconnection	Up scale(In case of R.T.D input), Stop operation when it is over ±5 % of its range		
Control mode	Operation method selection	Fix Control / Program Control		
Control output	Temperature	SSR/SCR 4 - 20 mA d.c	SSR (Pulse Voltage)	
	Humidity	SSR/SCR 4 - 20 mA d.c	SSR (Pulse Voltage)	
Control Action	Pattern	100 patterns (1 pattern/100 segments)		
	Segment	6,000 max segments	2,000 max segments	
	P.I.D group	16 Groups (Temp 4 zones x Humidity 4 zones)		
	Auto Tuning	Auto Tuning according to SV(Setting Value)		
	Proportional Band	0.00 ~ 100.00 % 0.00% = ON/OFF control	Temp. : 0.00 ~ 600.00 °C Humidity : 0.00 ~ 200.00 % 0.00% = ON/OFF control	
	Integral Time	0.0 ~ 6.000 sec (0 sec = OFF)		
	Derivative Time	0.0 ~ 6.000 sec (0 sec = OFF)		
	ON/OFF control	Set the Proportional Band as 0.0		
	Direct/Reverse action	Select Direct or Reverse action in control output.		
	ON/OFF Hysteresis	0.1 ~ 300 °C	0.1 ~ 600.0 °C	
		(In case of humidity, it is a web bulb temperature or converted value)		
Retransmission Output	Temp · Humidity	4 - 20 mA d.c, Select among PV,SV and MV(Manipulated Value)		
	Scaling	Perform scaling of the High · Low deviation range 4 - 20 mA d.c automatically		
Alarm Setting	Setting Alarm	System Alarm : 4 points Alarm per pattern : 4 points		
	Alarm type	Including High/Low /Low deviation alarm etc. 20 types of alarm are available.		
	Process Alarm	Temp. : -100.0 ~ 200.0 °C	Temp. : -100.0 ~ 500.0 °C	
		Humidity : 0.0 ~ 100.0 % RH		
	Deviation Alarm	Temp. : -300.0 ~ 300.0 °C	Temp. : -600.0 ~ 600.0 °C	
		Humidity : 0.0 ~ 100.0 % RH		
Hysteresis	Temp. : 0.0 ~ 300.0 °C	Temp. : 0.0 ~ 600.0 °C		
	Humidity : 0.0 ~ 100.0 % RH	Humidity : 0.0 ~ 100.0 % RH		
Storage against Power failure	Memory	Internal Flash Memory and FRAM		
	Memory function	Program Information and SV(Setting Value) backup and restoration. Storage of Temperature-Humidity setting value and PV		

8.6 Touch LCD

Model	TH500	TH300
Standard	Color STN LCD 144.78 (5.7")	TFT LCD 88.9 mm(3.5")
Resolution	320 X RGB X 240	320 X RGB X 240
Life span of back light	LED Back light (Approx. 40,000 hrs)	Edge light L.E.D (Approx. 40,000 hrs)
Touch type	Resistive Operation(4 Wires)	Resistive Operation(4 Wires)
Language	Korean/English, English/Chinese(Simple), English/Chinese(Traditional)	

8.7 Operation Environment

Model	TH500	TH300
Usable surrounding temperature	0 ~ 50 °C	
Usable surrounding humidity	20 ~ 90 % R.H(No condensation)	
Storage Temperature	-25 °C ~ 70 °C	
Vibration	10-55 Hz, amplitude : 0.75 mm, 3 directions 4 times, 5 min/cycle	
Shock	147 %g, 3 directions 3 times	
Dimension	183(W) X 144(H)	96(W) X 96(H)
Weight	Approx. 2.35 Kg(Including packing materials)	Approx. 0.85 Kg(Including packing materials)

9 ACCESSORIES (Sold Separately)

EM310 USB Memory Storage Device

- USB adaptor whose data is stored on USB memory stick after connecting between TH500/TH300 and EM310 through RS232.
- Data storage device to store internal nonvolatile data in rotation without USB memory stick.



9.1 Specification

Model	EM310
Power Supply Voltage	24 V d.c, 500 mA
Communication Method	Asynchronous Serial Communication(RS232C)
Communication Speed	max 38400 bps
Communication Distance	max 5 m
How to setting	Operate the front switch
Storage Medium	Memory stick (USB MERORY STICK)
File System	FAT16, 32
Inner Memory	32 Mb (Nonvolatile)

9.2 Name of each part

Name	Description
USB	The place where insert USB Stick
POWER	Red LED for displaying power supply
ACT	Green LED for displaying data storage(Flickering in case of recording)
DUMP	Copy button (When touching DUMP button, data on inner memory will be copied to USB memory stick.
CLEAR	Inner memory delete button (When touching CLEAR button more than 3 min, data on inner memory will be deleted.

9.3 Dimension and Panel Cutout

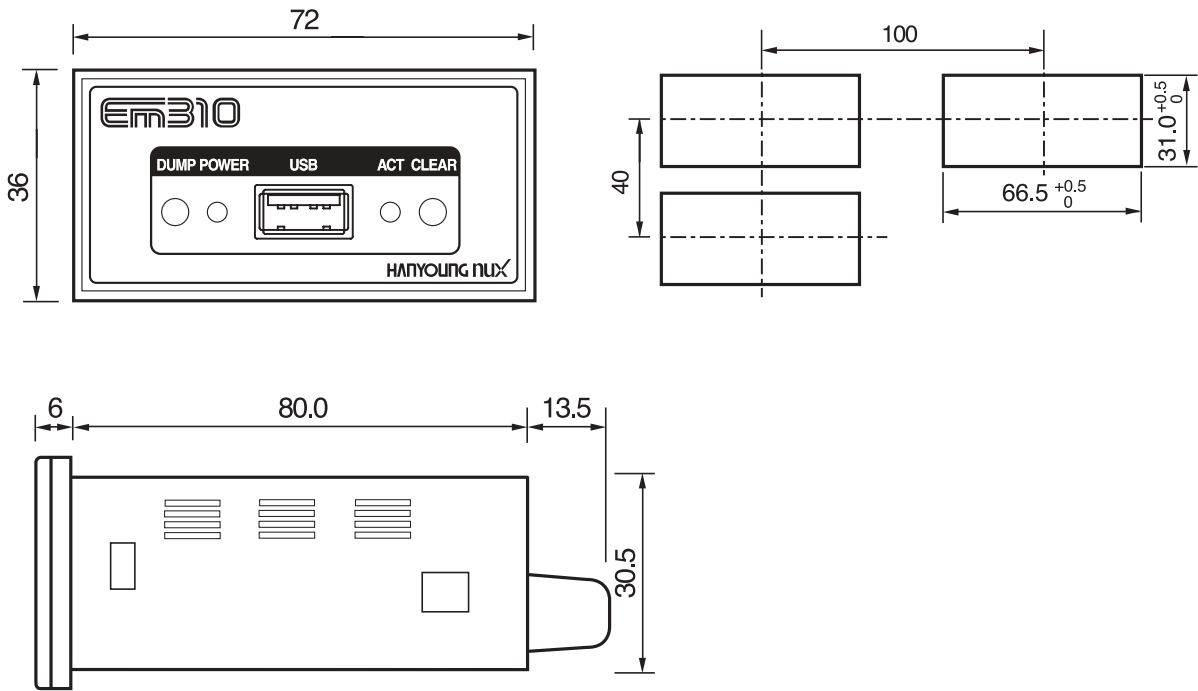

9.4 Connection Diagram

